



Model FA-30/18/PA/H Elevated Campfire Cooksite

- **Flanged firering for strength and safety**
- **Heat shield for added protection from hot firering perimeter surface**
- **Patented, infinitely adjustable cooking grate**
- **Structurally reinforced grate is virtually indestructible**
- **Grate tips back for maximum access to fire**
- **Unique handle design allows easy positioning of grate and keeps handle grips outside of firering**
- **Public use-type spring grips of coiled steel bar**
- **“Bottomless” design with aggregate fill installs on any surface**
- **Recommended aggregate fill raises fire to comfortable working height**
- **Utility shelf option**
- **Quality construction throughout**

AVAILABLE OPTIONS

Utility Shelf

SPECIFICATIONS:

- **Model FA-30/18/PA/H** has a 34" overall dia. heat shield mounted to a 32" overall dia. x 16-7/8" tall steel ring.
- The ring is constructed from 3/16" thick steel with a formed (NOT WELDED) 1" flanged lip at the top of the ring to provide strength to the ring and eliminate the vertical edge. 9/16" dia. holes spaced around the ring at fire level and the bottom perimeter provide draft and drainage.
- 270 sq. in. grate is constructed from 5/8" dia. A-36 steel bars around the perimeter, 3/4" dia. A-36 steel bars for the handles and 1/2" dia. A-36 steel bars to provide the grate surface. Grate is secured to firering by two vertical 3/4" dia. A-36 steel bars that allow 7" of infinite adjustment within and above the ring and allow the grate to hang in a nonobtrusive manner when tipped back for cleaning, fire building or when not needed.
- Grate is structurally reinforced to withstand the weight of two or more people standing on it without permanently deforming or bending.
- Grate is provided with two adjusting handles with substantial spring grips suitable for public use made from 1/8" x 1/2" steel flat bar that remain outside the fire barrier at all positions.
- Firering is provided with an 8" high heat shield constructed from 10 ga. steel welded on to new firerings. Heat shield provides a 7/8" cooling air gap around the area of the firering exposed to the fire (indicated by /H in model no., e.g. FA-30/18/PA/H).
- Firering is designed to be filled with customer supplied coarse aggregate fill to a level 9" below top of ring to raise fire to proper cooking height and protect hard surfaces from heat damage.
- Unit is provided with three 1/2" dia. anchor pins for concrete embedment (indicated by /PA in model no., e.g. FA-30/18/PA/H).
- Entire unit is finished in high temperature, heat resistant, nontoxic black enamel.
- **Optional:** Firering is provided with a 3/16" x 7-1/8" x 9-5/8" steel plate utility shelf. (Add /S to end of model no., e.g. FA-30/18/PA/H/S.)

RJ Thomas Mfg. Co., Inc.

PO Box 946 • Cherokee, IA 51012-0946 • PH: 712-225-5115 • 800-762-5002 • FAX: 712-225-5796
E-mail: pilotrock@rjthomas.com • Web Site: <http://www.pilotrock.com>

© 2017 RJ Thomas Mfg. Co., Inc. PILOT ROCK® Park Products is a registered trademark of RJ Thomas Mfg. Co., Inc.

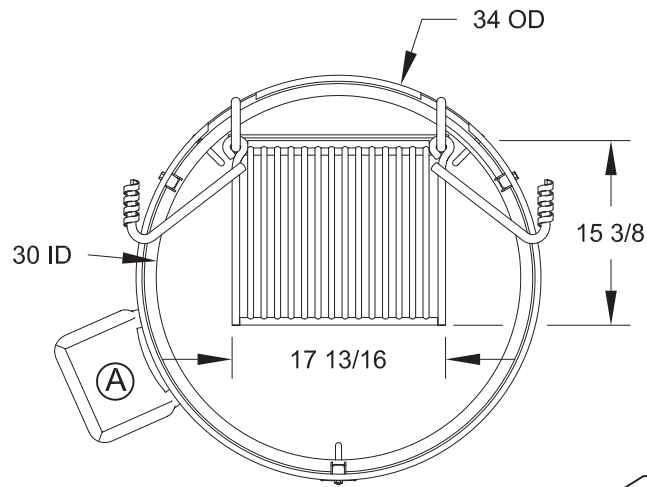

GRATE FLIPS COMPLETELY
OUT OF FIRERING FOR EASIER
CLEANING AND FIRE BUILDING

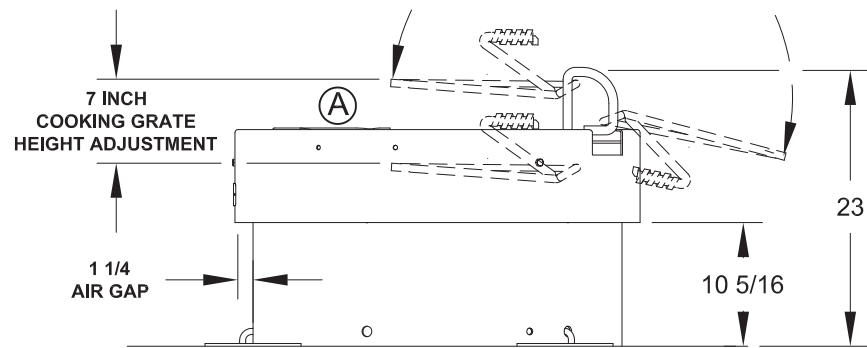

(A) OPTIONAL UTILITY SHELF
- ADD /S TO MODEL NUMBER

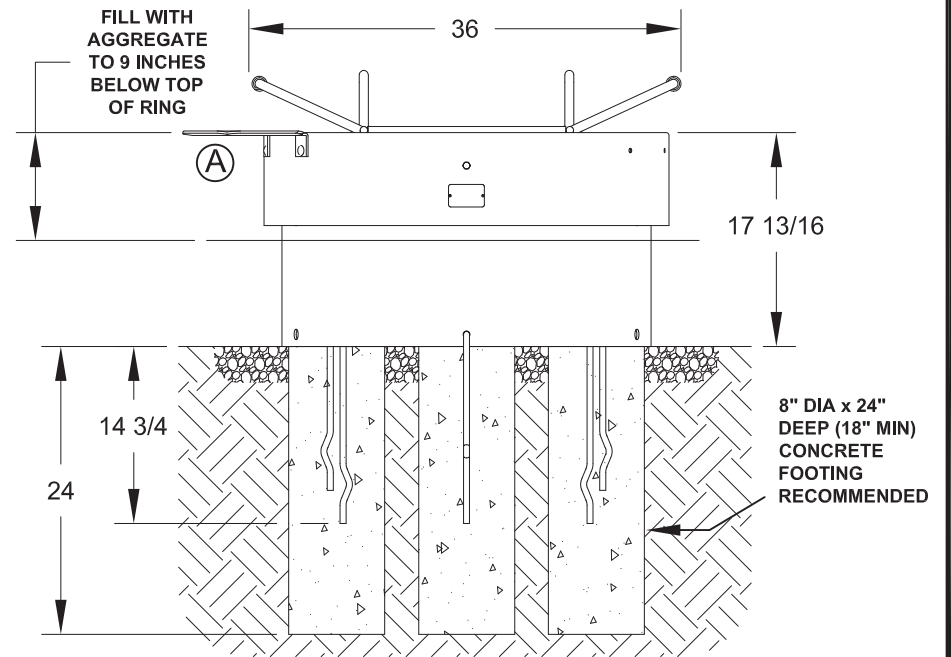
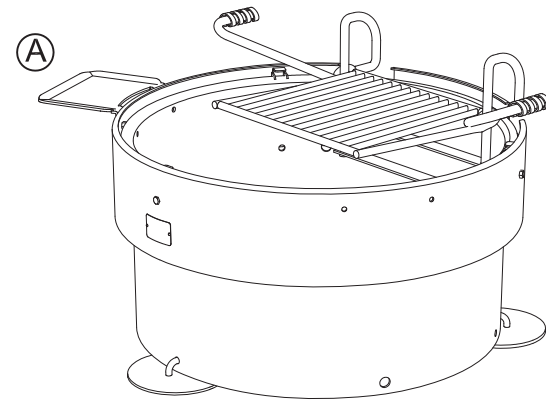

ALL DIMENSIONS IN INCHES

RJThomas Mfg. Co., Inc.
P.O. Box 946 • Cherokee, IA 51012-0946

DRAWN BY
WWM

TITLE MODEL FA-30/18/PA/H CAMPFIRE RING WITH INFINITELY ADJUSTABLE COOKING GRATE AND HEAT SHIELD - SHOWN WITH OPTIONAL MODEL S5 UTILITY SHELF

DATE 11-18-14

DWG. NO. **AI-2061**