



*Model FS-30/18/H/S Wheelchair Accessible  
Campfire Ring with Heat Shield and Optional Utility Shelf  
(Note: anchor pins not used in this installation and cooking grate is  
tipped outside of firering in this photo.)*

- **Flanged firering for strength and safety**
- **Heat shield for added protection from hot firering perimeter surface**
- **Two side heights available**
- **Single level, hinged cooking grate**
- **Grate swings outside of ring when not in use for better access to the fire and an open campfire effect**
- **Public use-type spring grips of coiled steel bar**
- **Elevated cooking grate and firebed conform to ADA guidelines**
- **Required aggregate fill protects site surfaces such as paver blocks, cement, and asphalt from heat damage**
- **Utility shelf option**
- **Quality construction throughout**

#### AVAILABLE OPTIONS

Utility Shelf

#### SPECIFICATIONS:

- **Model FS-30/18/PA/H** firering side height is 16-7/8".
  - **Model FS-30/24/PA/H** firering side height is 23-3/8".
  - 32" overall dia. firering is constructed from 3/16" thick steel with a formed (NOT WELDED) 1" flanged lip around the top of the ring and ten 1" dia. drain/draft/anchor holes located around the perimeter.
  - 290 sq. in. cooking grate is constructed from 5/8" dia. A-36 steel bars around the perimeter, 3/4" dia. A-36 steel bar for the handle, and 1/2" dia. A-36 steel bar for the grate bars.
  - Grate is attached to and hinge upon two tightly formed eyelets made from 5/8" dia. A-36 steel bar that makes a mechanically secure theft-proof attachment.
  - Grate is provided with two substantially constructed spring grips suitable for public use made from 1/8" x 1/2" flat bar (not wire springs). Unit is designed to allow reasonably easy access to the cooking grate from a wheelchair.
  - Firering is provided with an 8" high heat shield constructed from 10 ga. steel welded on to new firerings. Heat shield provides a 7/8" cooling air gap around the area of the firering exposed to the fire (indicated by /H in model no., e.g. FS-30/18/PA/H).
  - Firering is designed to be filled with customer supplied aggregate fill to a level 9" above ground level to raise fire to proper height and protect hard surfaces from heat damage. Model FS-30/18/PA/H requires 9" of fill, Model FS-30/24/PA/H requires 14-3/8" of fill. These levels conform with ADA guidelines of a minimum of 9" of fill above ground level.
  - Unit is provided with three 1/2" dia. anchor pins for concrete embedment (indicated by /PA in model no., e.g. FS-30/18/PA/H).
  - Entire unit is finished in high temperature, heat resistant, nontoxic black enamel.
  - **Optional:** Firering shall be provided with a 3/16" x 7-1/8" x 9-5/8" steel plate utility shelf. (Add /S to model no., e.g. FS-30/18/PA/H/S.)
- Note: The optional utility shelf fits both firering and optional heat shield. (When ordering both options, add /H/S to model no., e.g. FS-30/18/PA/H/S.)

**RJ Thomas Mfg. Co., Inc.**

PO Box 946 • Cherokee, IA 51012-0946 • PH: 712-225-5115 • 800-762-5002 • FAX: 712-225-5796  
E-mail: pilotrock@rjthomas.com • Web Site: <http://www.pilotrock.com>

© 2019 RJ Thomas Mfg. Co., Inc. PILOT ROCK® Park Products is a registered trademark of RJ Thomas Mfg. Co., Inc.

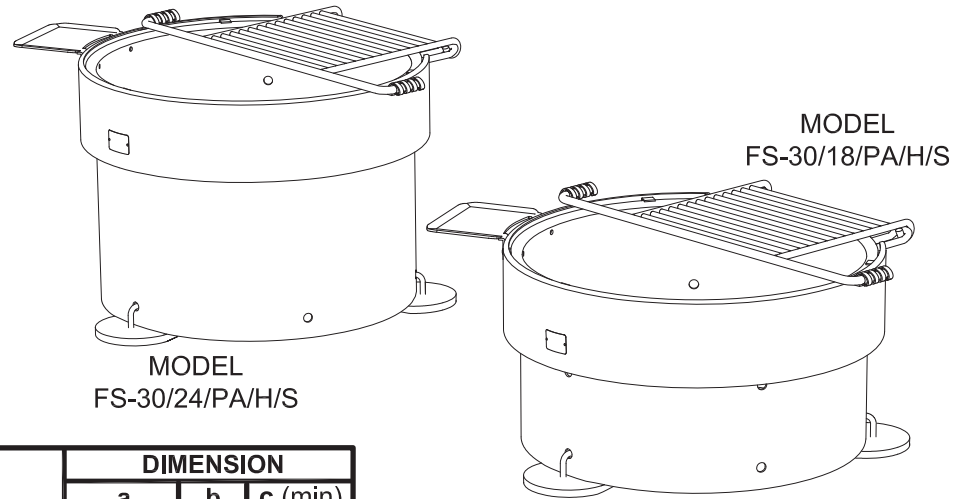
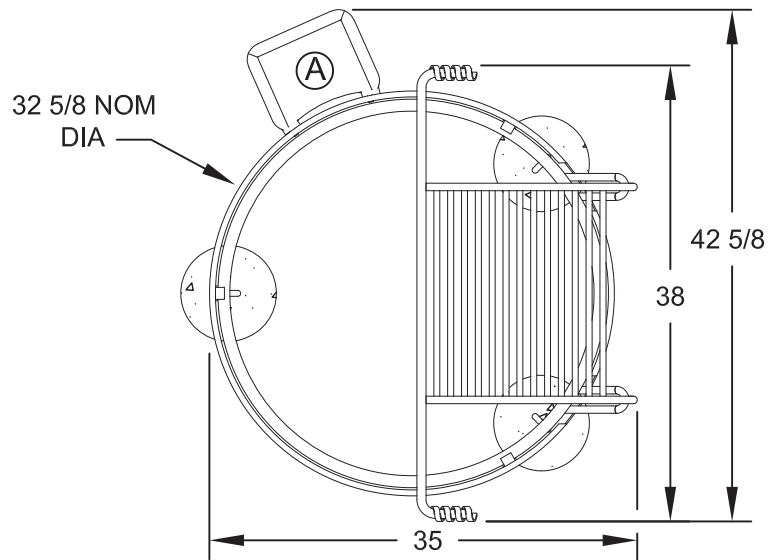

MODEL NUMBER	DIMENSION		
	a	b	c (min)
FS-30/18/PA/H	16-7/8	18	9
FS-30/24/PA/H	23-3/8	24	14-3/8

Ⓐ OPTIONAL UTILITY SHELF  
- ADD /S TO MODEL NUMBER

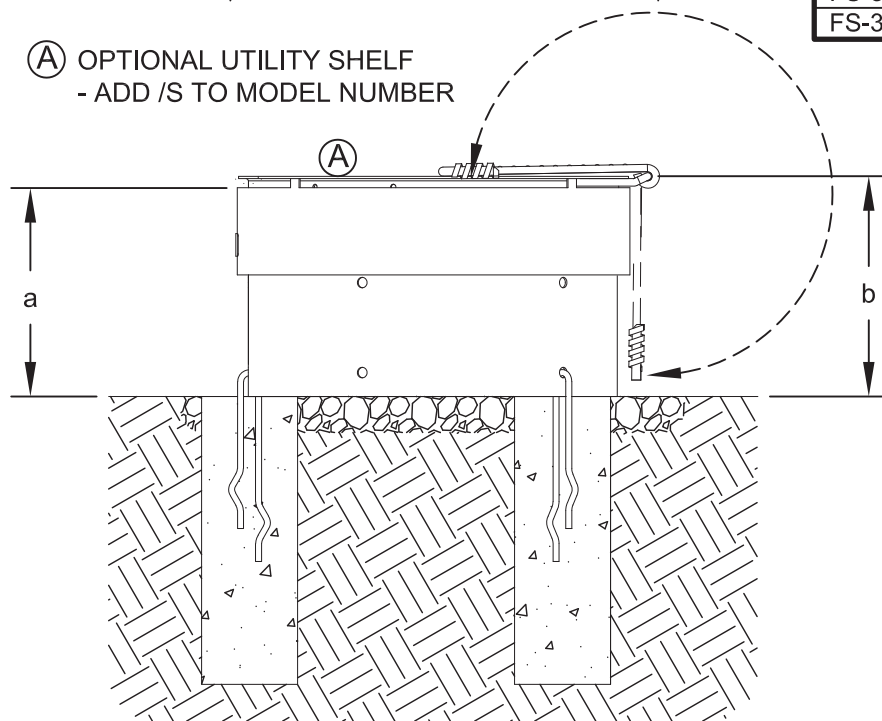

FILL TO RECOMMENDED HEIGHT (c) ABOVE GROUND LEVEL WITH COARSE AGGREGATE FILL (CONFORMS TO ADA GUIDELINES OF MIN 9" HEIGHT ABOVE GROUND FOR FIRE BASE)

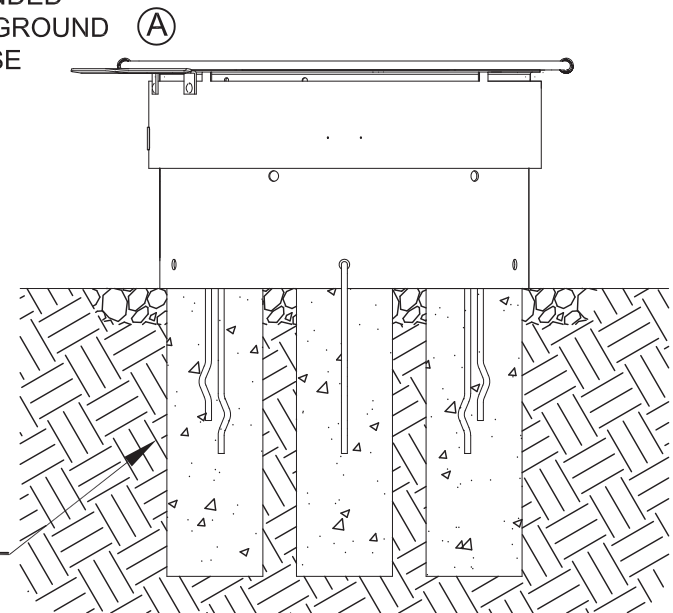

8" DIA. x 24" DEEP (18" MIN) CONCRETE FOOTING RECOMMENDED

ALL DIMENSIONS IN INCHES

ALL DIMENSIONS IN INCHES

**RJThomas Mfg. Co., Inc.**  
P.O. Box 946 • Cherokee, IA 51012-0946

DRAWN BY  
**WWM**

TITLE FS-30 SERIES WHEELCHAIR ACCESSIBLE CAMPFIRE RING WITH PIN ANCHORS AND HEAT SHIELD; TWO MODELS WITH TWO SIDE HEIGHTS -SHOWN WITH OPTIONAL UTILITY SHELF

DATE 9-22-08

DWG. NO. **AI-1417**