



Model FSW-30/9TB Campfire Ring with swivel cooking grate.

(Below) Grate shown rotated out of the firing.



- **Cooking grate rotates 180 degrees from over the fire to completely out of the fire**
- **Handle is never over the fire**
- **Flanged firing for strength and safety**
- **Public use-type spring grips of coiled steel bar**
- **Quality construction throughout**

SPECIFICATIONS:

- The cooking grate of the **FSW Series** firing is designed to rotate 180 degrees from a position over the fire, to a position completely out of the fire.
 - 32" overall dia. firing is constructed from 3/16" thick steel with a formed (NOT WELDED) 1" flanged lip around the top of the ring and ten 1" dia. drain/draft/anchor holes located around the perimeter.
 - **Model FSW-30/7/TB** firing side height is 7-3/8" (indicated by "/7" in model no., e.g. FSW-30/7/TB).
 - **Model FSW-30/9/TB** firing side height is 9" (indicated by "/9" in model no., e.g. FSW-30/9/TB).
 - **Model FSW-30/11/TB** firing side height is 11-3/8" (indicated by "/11" in model no., e.g. FSW-30/11/TB).
 - The single level, 300 sq. in. cooking grate is constructed from 1/2" dia. A-36 steel bars around the perimeter, 5/8" dia. A-36 steel bar for the handle, and 1/2" dia. A-36 steel bar for the grate bars.
 - Grate is provided with a substantially constructed spring grip suitable for public use made from 1/8" x 1/2" flat bar (not wire springs).
 - Grate is mounted on a 2-3/8" OD tube allowing it to rotate on a horizontal plane out of the firing. Two welded-on stops limit rotation to 180° to prevent the handle entering the area over the fire. Minimal force is required to move grate.
 - Ring is provided with hinged anchoring device to allow ring to tip upward for easy cleaning. Two 1/2" dia. steel "U" anchor pins with deformed ends insert 15" into concrete footings (indicated by "/TB" in model no., e.g. FSW-30/7/TB).
 - Entire unit is finished in high temperature, heat resistant, nontoxic black enamel paint.
 - **Option:** Firing is provided with an 8" high heat shield constructed from 10 ga. steel welded on to new firings. Heat shield provides a 7/8" cooling air gap around the area of the firing exposed to the fire (indicated by "/H" in model no., e.g. FSW-30/11/TB/H).
 - **Optional:** Firing is provided with a 3/16" x 7-1/8" x 9-5/8" steel plate utility shelf. (Add "/S" to model no., e.g. FSW-30/7/TB/S.)
- Note:** The optional utility shelf fits both firing and optional heat shield. (When ordering both options, add "/H/S" to model no., e.g. FSW-30/7/TB/H/S.)

AVAILABLE OPTIONS

**Utility Shelf
Heat Shield**

RJ Thomas Mfg. Co., Inc.

PO Box 946 • Cherokee, IA 51012-0946 • PH: 712-225-5115 • 800-762-5002 • FAX: 712-225-5796
E-mail: pilotrock@rjthomas.com • Web Site: <http://www.pilotrock.com>

© 2018 RJ Thomas Mfg. Co., Inc. PILOT ROCK® Park Products is a registered trademark of RJ Thomas Mfg. Co., Inc.

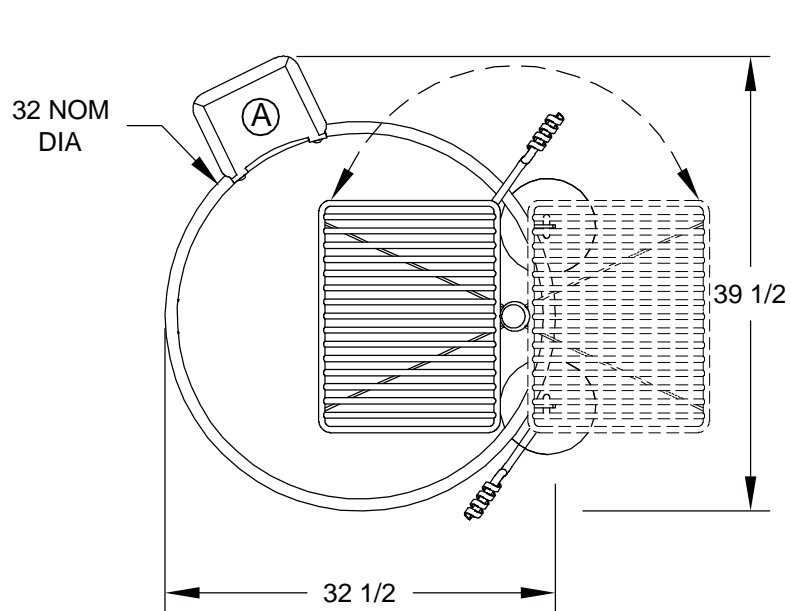

MODEL FSW-30/9/TB/S

MODEL FSW-30/11/TB/S
- SHOWN IN
TIPPED BACK
POSITION FOR
CLEANING

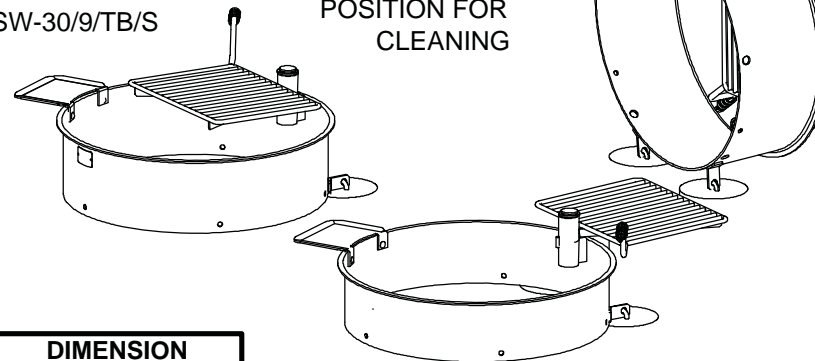

MODEL FSW-30/7/TB/S
SHOWN WITH GRATE
ROTATED

MODEL NUMBER	DIMENSION	
	a	b
FSW-30/7/TB	7-3/8	13
FSW-30/9/TB	9	15 11/16
FSW-30/11/TB	11-3/8	18 1/8

(A) OPTIONAL UTILITY SHELF - ADD /S TO MODEL NUMBER

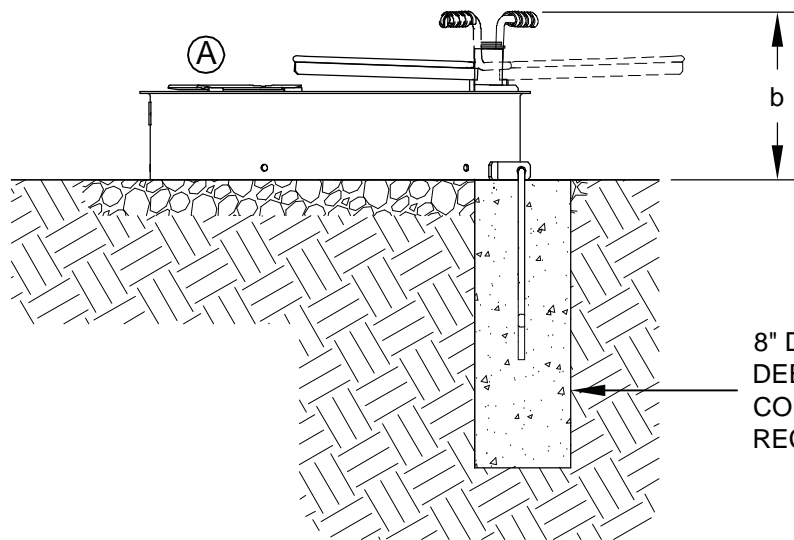

8" DIA X 24"
DEEP (18" MIN)
CONCRETE FOOTING
RECOMMENDED

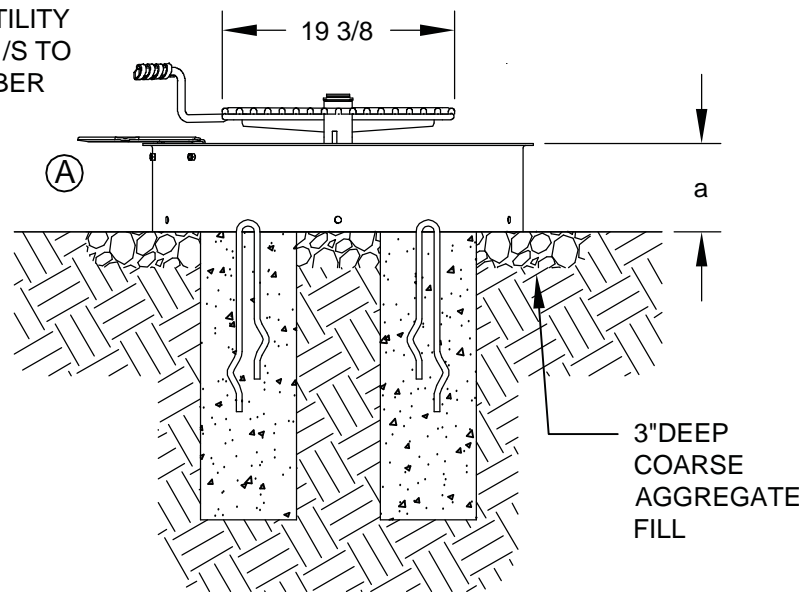

3" DEEP
COARSE
AGGREGATE
FILL

ALL DIMENSIONS IN INCHES

RJThomas Mfg. Co., Inc.
P.O. Box 946 • Cherokee, IA 51012-0946

DRAWN BY
WWM

TITLE FSW-30 SERIES CAMPFIRE COOKSITE WITH SWIVEL COOKING GRATE
AND TIP-BACK ANCHORS; THREE MODELS WITH 3 SIDE HEIGHTS

DATE 11-26-13

DWG. NO. AI-2054