

# FX-48 Large Campfire Ring only - No Grate



*Model FX-48/9/AL/S Campfire Ring only- No Grate.  
Shown with optional shelf and optional spade anchors.*

- **Designed to contain large fires for group activities**
- **Flanged firering for strength and safety**
- **No cooking grate**
- **Three fire barrier heights available**
- **Pin anchors embedded in concrete footings provide permanent location**
- **“Bottomless” design installs without concrete pad**
- **Quality construction throughout**

## **SPECIFICATIONS:**

- **Model FX-48/7/PA** has a 7-3/8" high fire barrier.
- **Model FX-48/9/PA** has a 9" high fire barrier.
- **Model FX-48/11/PA** has a 11-3/8" high fire barrier.
- The 48" overall dia. ring is fabricated from 3/16" thick steel with a formed (NOT WELDED) 1" flanged lip around the top of the ring, with 9/16" draft holes spaced around the bottom perimeter.
- Ring is provided with four 1/2" dia. anchor pins for concrete embedment (indicated by /PA in model no., e.g. FX-48/7/PA).
- Entire unit is finished in high temperature, heat resistant, nontoxic black enamel paint.
- **Optional:** Firering is provided with a 3/16" x 7-1/8" x 9-5/8" steel plate utility shelf. (Add /S to model no., e.g. FX-48/7/PA/S.)
- **Optional:** Ring is provided with four heavy anchors of 1-3/4" x 1-3/4" x 3/16" A-36 steel angle with welded-on spades of 1/8" thick steel to permanently anchor unit to ground (indicated by /AL in model no., e.g. FX-48/7/AL).

## **AVAILABLE OPTIONS**

- **Utility shelf**
- **Spade anchors**

**RJ Thomas Mfg. Co., Inc.**

PO Box 946 • Cherokee, IA 51012-0946 • PH: 712-225-5115 • 800-762-5002 • FAX: 712-225-5796  
E-mail: [pilotrock@rjthomas.com](mailto:pilotrock@rjthomas.com) • Web Site: <http://www.pilotrock.com>

© 2017 RJ Thomas Mfg. Co., Inc. PILOT ROCK® Park Products is a registered trademark of RJ Thomas Mfg. Co., Inc.

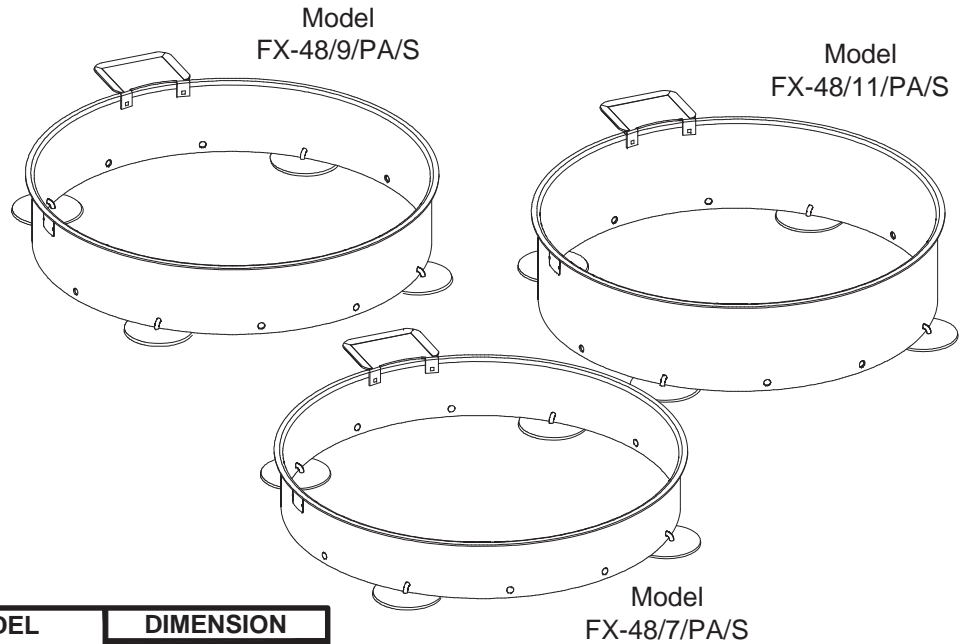
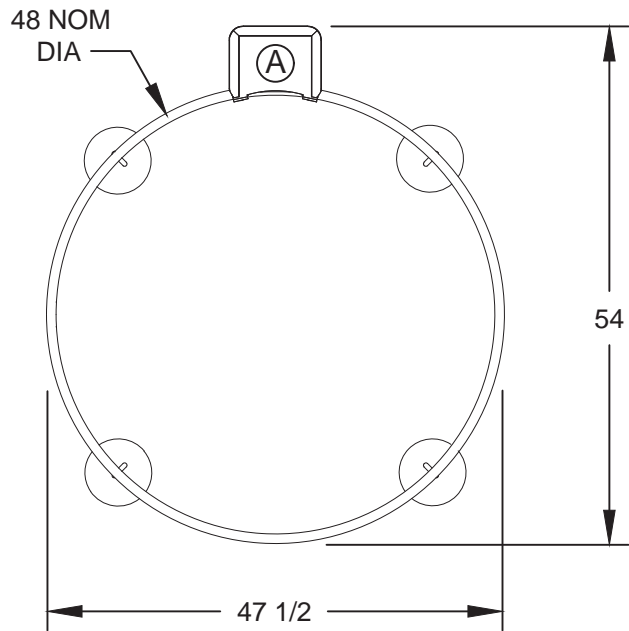

MODEL NUMBER	DIMENSION	
	a	b
FX-48/7/PA	7-3/8	8-1/8
FX-48/9/PA	9	9-3/4
FX-48/11/PA	11-3/8	12

(A) OPTIONAL UTILITY SHELF - ADD /S TO MODEL NUMBER

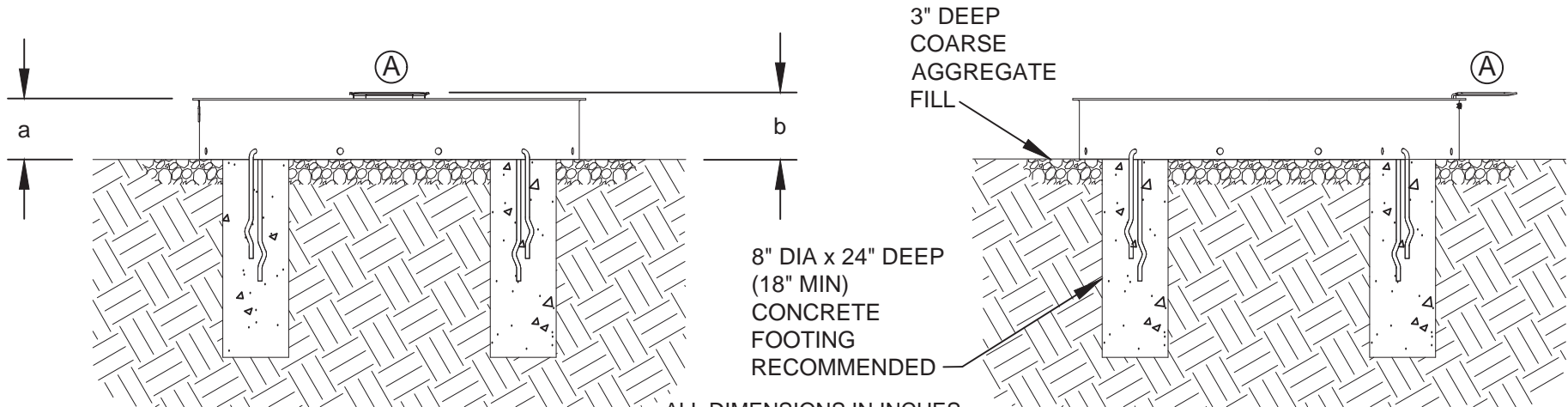

ALL DIMENSIONS IN INCHES

**RJThomas Mfg. Co., Inc.**  
P.O. Box 946 • Cherokee, IA 51012-0946

DRAWN BY  
**MFI**

TITLE **FX-48 SERIES CAMPFIRE RING WITH NO GRATE; 3 MODELS WITH 3 SIDE HEIGHTS**  
-SHOWN WITH OPTIONAL UTILITY SHELF

DATE 10-5-15

DWG. NO. **AI-2074**