



*Model HRP/CY-8 Hitchin' Post Group Bike Rack, surface mount with yellow powder coat finish. Holds eight bikes.*

- **Secures up to eight bikes**
- **Strong 2-3/8" diameter tubing**
- **Hot dip galvanized after fabrication for long lasting finish**

## **SPECIFICATIONS:**

- **Model HRP** Hitchin' Post bike rack is constructed from 2-3/8" dia. 11 ga. (.115) wall steel tubing with two 6" inside radius die-formed bends creating an inverted "U" shape.
- **Model HRP** group bike rack is designed to have an overall height of 36-7/16" and an overall width of 31-1/8".
- The vertical legs of the bike racks have welded flanges with two holes for 3/8" carriage bolt fasteners (included) for securing the racks to surface channels on 30" centers allowing two bikes to be secured to each rack.
- Racks are bolted to two 1" x 4" x 10 ga. formed steel surface channels with 7/16" dia. holes for anchors.
- All fasteners for assembly are included.
- **Model HRP-6** group bike rack is 66" long and holds up to 6 bikes using three Hitchin' Post racks mounted to rails.
- **Model HRP-8** group bike rack is 96" long and holds up to 8 bikes using four Hitchin' Post racks mounted to rails.
- Bike rack components are hot-dip galvanized after fabrication to ASTM-A123 to maintain an average zinc coating of 2.0 oz. per sq. ft. of surface area (indicated by "/G" in model no. HRP/G-6).
- **Optional:** A set of four 3/8" dia. x 5" heavy duty screw anchors for concrete surface mounting of **Model HRP-6** are available (order **Model ANC2-4** anchor kit as an additional item).
- **Optional:** A set of six 3/8" dia. x 5" heavy duty screw anchors for concrete surface mounting of **Model HRP-8** are available (order **Model ANC2-6** anchor kit as an additional item).
- **Optional:** Color choices of powder coated steel. For optional colors choices see Specification Bulletin #SPC-CO-001.
- **Optional:** Color choices of thermo plastic coated steel. For optional colors choices see Specification Bulletin #SPC-CO-001.

## **AVAILABLE OPTIONS**

- **Two sizes to choose from, 6 or 8 bikes**
- **Powder Coat Finish in choice of colors**
- **Thermo plastic coated finish in choice of colors**

**RJ Thomas Mfg. Co., Inc.**

PO Box 946 • Cherokee, IA 51012-0946 • PH: 712-225-5115 • 800-762-5002 • FAX: 712-225-5796  
E-mail: pilotrock@rjthomas.com • Web Site: <http://www.pilotrock.com>

© 2012 RJ Thomas Mfg. Co., Inc. PILOT ROCK® Park Products is a registered trademark of RJ Thomas Mfg. Co., Inc.

HRP-8  
HOLDS 8 BIKES

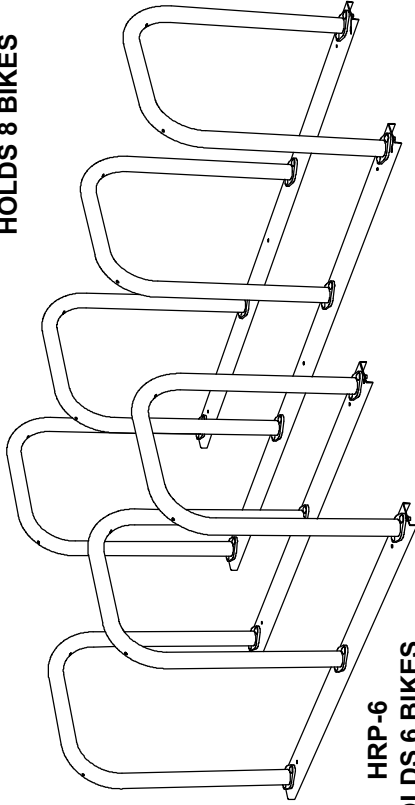

HRP-6  
HOLDS 6 BIKES

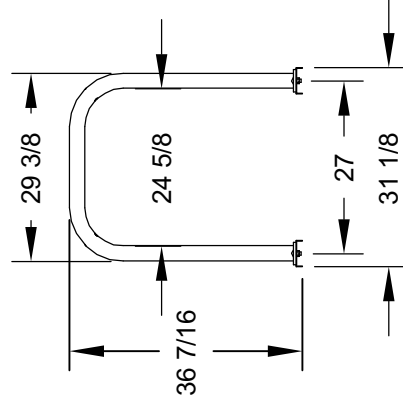
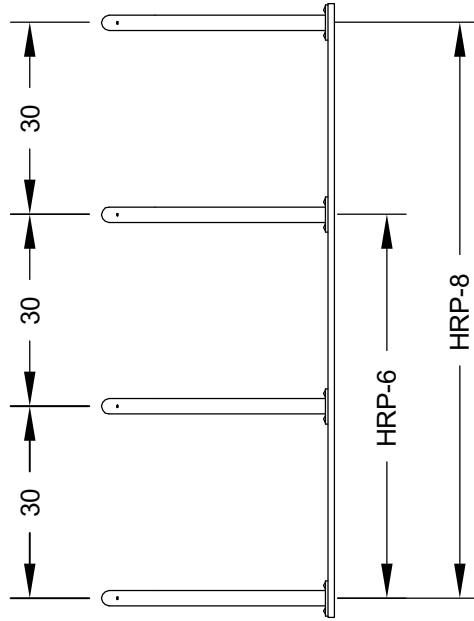
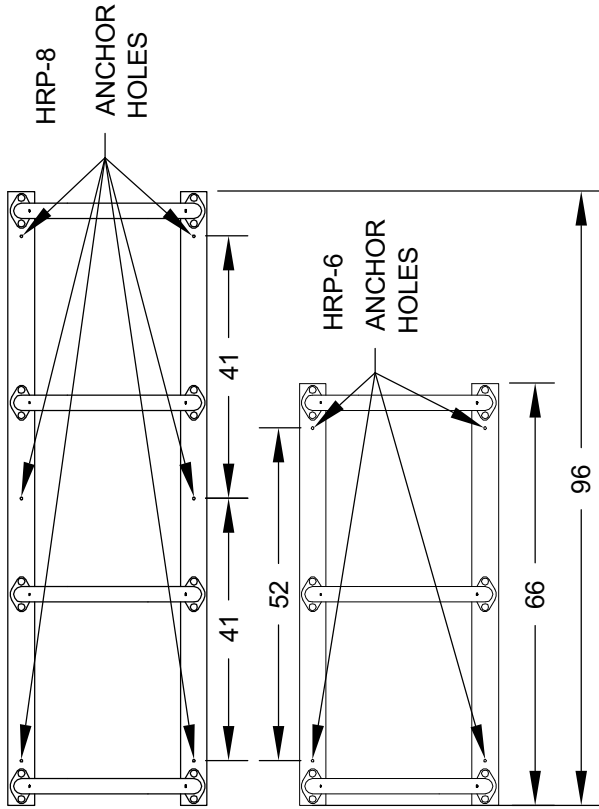

ALL DIMENSIONS IN INCHES

**RJ Thomas Mfg. Co., Inc.**  
P.O. Box 946 • Cherokee, IA 51012-0946

DRAWN BY  
**WWM**

TITLE MODELS HRP-6 AND HRP-8 HITCHIN' POST GROUP BIKE RACK

DATE 3-26-13

DWG. NO. **AI-2050**