



*Model LDW-36/18/PA Double Wall Firering with four level adjustable grate and pin anchors, 17-1/2 in. high fire barrier*

- **Double-walled firering for strength and safety**
- **Four levels of cooking grate height adjustment**
- **Adjustment panels shield grips and hands from heat**
- **Public use-type spring grips of coiled steel bar**
- **Pin anchors embedded in concrete footings provide permanent location**
- **“Bottomless” design installs without concrete pad**
- **Quality construction throughout**

#### **SPECIFICATIONS:**

- **Model LDW-36/18/PA** is constructed from a 3/16" thick 31-3/4" ID plate steel inner firering centered in a 1/8" thick 36-1/16" ID plate steel outer ring providing an air gap of 2". Outer ring has a formed (NOT WELDED) 1" flanged lip around the top of the ring flange. Three formed steel angles welded between rings maintain spacing. Ring is welded to two 3/16" plate steel grate support panels for overall dimensions of 38-1/8" wide by 36-7/16" long, and 26-9/16" high. Fire barrier is 17-5/16" high. Both rings have ten 9/16" dia. drain/draft holes through both rings located around the perimeter.
- 300 sq. in. cooking grate is constructed from 1/2" dia. A-36 steel bar with grate bars spaced 1-1/8" on centers. Grate is constructed with a one-piece wrap-around perimeter bar of 1/2" dia. A-36 steel bar with formed corners.
- Grate is securely welded to two 5/8" dia. steel support bars made to adjust in vertical slots die punched in the heat panels. Grate handles are provided with two substantially constructed spring coil grips suitable for public use made from 1/8" x 1/2" flat steel bar (not wire springs).
- Grate is supported in four locations by two 3/16" plate steel heat panels. Side heat panels have 90° bends and edge flares die-formed into one vertical edge adding strength to the entire unit and providing a heat shield for grate adjustment. Back panel of 3/16" plate steel is welded to heat panels.
- Three 1/2" dia. steel “U” anchor pins with deformed ends insert 15" into concrete footings (indicated by “/PA” in model no., e.g. LDW-36/18/PA).
- Entire unit is finished in high temperature, heat resistant, nontoxic black enamel.
- **Optional:** Firering is provided with a 3/16" x 7-1/8" x 9-5/8" steel utility shelf. (Add “/S” to model no., e.g. LDW-36/18/PA/S.)

#### **AVAILABLE OPTIONS**

Utility Shelf

**RJ Thomas Mfg. Co., Inc.**

PO Box 946 • Cherokee, IA 51012-0946 • PH: 712-225-5115 • 800-762-5002 • FAX: 712-225-5796  
E-mail: pilotrock@rjthomas.com • Web Site: <http://www.pilotrock.com>

© 2019 RJ Thomas Mfg. Co., Inc. PILOT ROCK® Park Products is a registered trademark of RJ Thomas Mfg. Co., Inc.

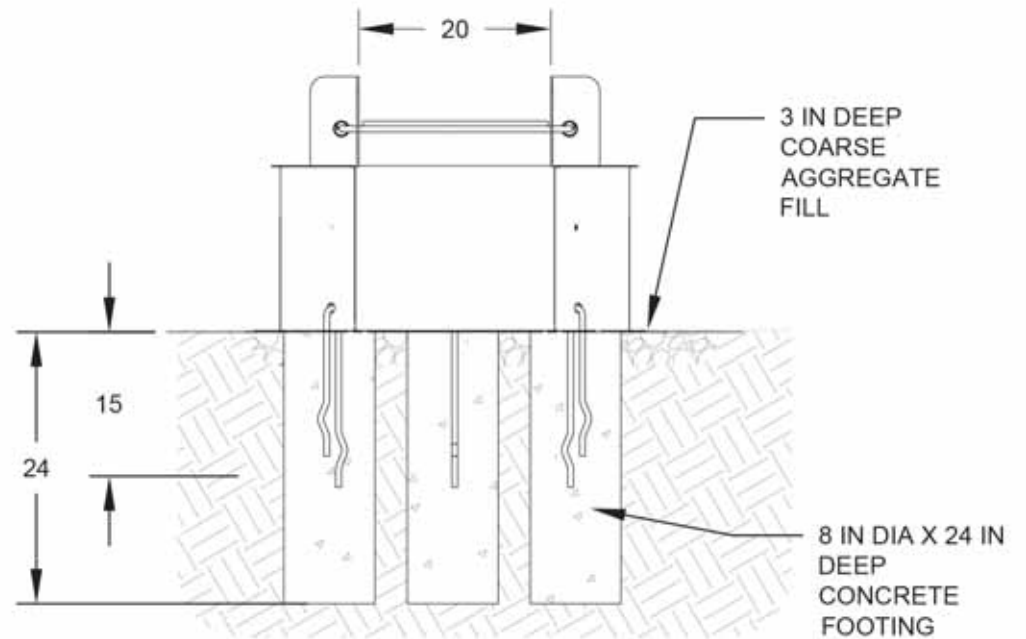
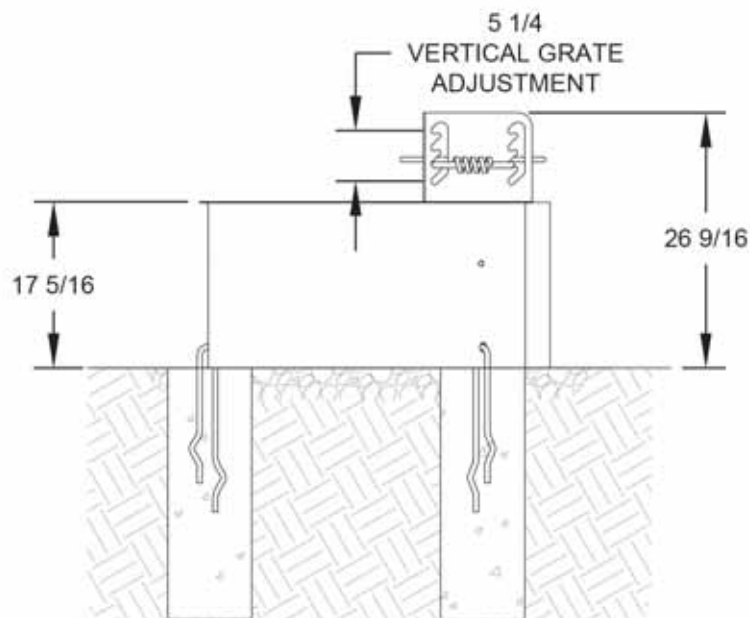
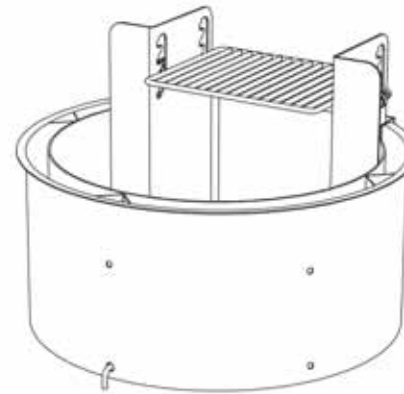
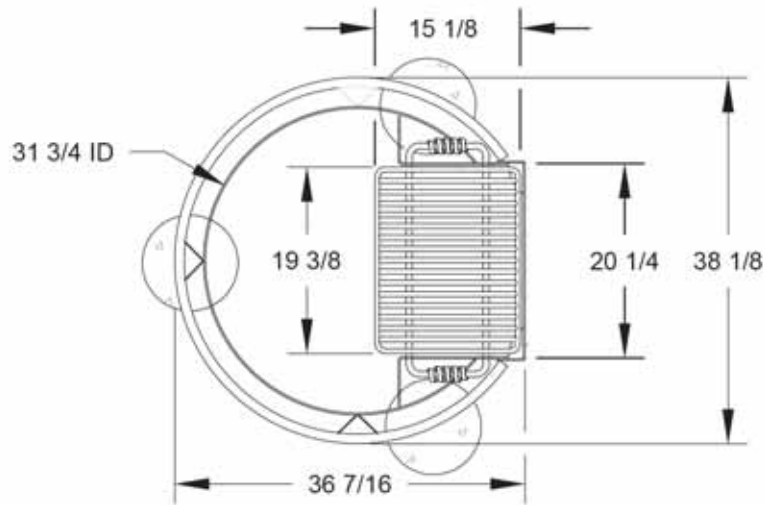

ALL DIMENSIONS IN INCHES

**RJThomas Mfg. Co., Inc.**  
P.O. Box 946 • Cherokee, IA 51012-0946

DRAWN BY  
**JGJ**

TITLE **MODEL LDW-36/18 DOUBLE WALL FIRERING WITH PIN ANCHORS**

DATE **06-07-2018**

DWG. NO. **AI-1894**