

Model LH-1 Lantern Holder



(Above) **Model LH/G-1A** Lantern Holder with galvanized finish and welded-on Wheelchair Accessible Hook.
 (Left) **Model LH/G-1** Lantern Holder with galvanized finish.

- **Heavy 2-3/8" diameter 11 ga. wall steel tubing**
- **1/2" diameter steel hook**
- **Hot dip galvanized finish**
- **Accessible model available**
- **Optional Utility Shelf**
- **Optional Rules Plate**
- **Optional Bolt-on Accessible Hook**

AVAILABLE OPTIONS

Powder Coat Finish in choice of colors

Optional Bolt-on Rules Plate



Optional Bolt-on Utility Shelf



Optional Bolt-on Accessible hook

SPECIFICATIONS:

- **Model LH-1 Series** lantern holders are constructed of 2-3/8" OD x 11 ga. wall tube with a 90 degree radius bend forming an overhang to provide clearance for campsite lighting devices to hang from an open hook made of 1/2" dia. round steel rod.
- **Model LH-1/A** includes all the features of model LH-1 plus an additional wheelchair accessible hook (indicated by "/A" in model no.) welded to the lantern holder at 54" above ground surface level to provide a wheelchair accessible position for hanging campsite lighting devices.
- Lantern holder is designed to be anchored 28" into a concrete footing which places the lantern hook 76" above ground surface.
- **Standard:** Lantern holder is hot dip galvanized after fabrication to ASTM-A123 to maintain an average zinc coating of 2.0 oz. per sq. ft. of surface area (indicated by "/G" in model no., e.g. LH/G-1 or LH/G-1A).
- **Optional Rules Plate:** A hot dip galvanized, 6" x 12" x 7 ga. steel plate with screws for attachment to lantern holder pole provides a surface for attachment of decals or adhesive signs posting park regulations, notices, and fees. Order Model RP/G as a separate item.
- **Optional Shelf:** A one-piece welded 14" x 20" x 10 ga. utility shelf with reinforcing gussets and a "U" clamp for attachment to the lantern holder pole is available. All fasteners are included. The shelf can also be retrofitted to any existing 2-3/8" OD round tube pole. Order Model LHS/G-1 as a separate item.
- **Optional Bolt-on Accessible Hook:** A 2-3/8" OD arm for a 1/2" dia. hook welded to a "U" clamp attaches to any 2-3/8" OD lantern holder pole providing a wheelchair accessible position for hanging campsite lighting devices. Order Model LHA-1 as a separate item.
- **Optional:** Color choices of powder coated finish for lantern holder and optional accessories. For optional colors choices see Specification Bulletin #SPC-CO-001.

RJThomas Mfg. Co., Inc.

PO Box 946 • Cherokee, IA 51012-0946 • PH: 712-225-5115 • 800-762-5002 • FAX: 712-225-5796
 E-mail: pilotrock@rjthomas.com • Web Site: <http://www.pilotrock.com>

© 2008 RJThomas Mfg. Co., Inc. PILOT ROCK® Park Products is a registered trademark of RJThomas Mfg. Co., Inc.

MODEL
LH/G-1

MODEL
LH/G-1/A

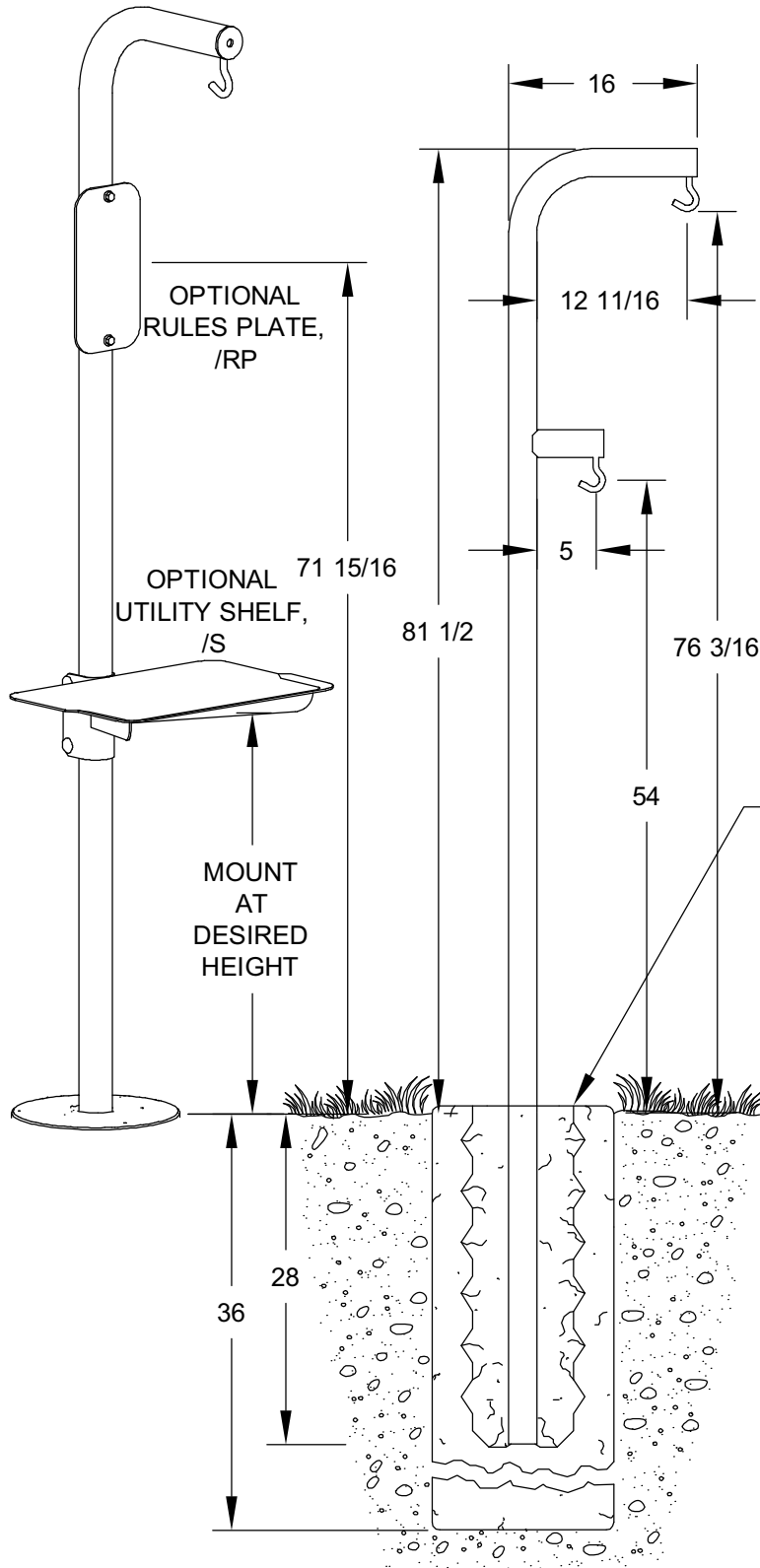

12" DIA.
MIN.
NOTE:
LOCAL SOIL
CONDITIONS
MAY REQUIRE
A LARGER
FOOTING
(CHECK LOCAL
CODES)

ALL DIMENSIONS IN INCHES

RJThomas
Mfg. Co., Inc.
P.O. Box 946
Cherokee, IA 51012

TITLE MODEL LH-1 SERIES LANTERN HOLDERS. LH-1 SHOWN WITH
OPTIONAL UTILITY SHELF AND RULES PLATE. MODEL LH-1/A
WHEEL CHAIR ACCESSIBLE LANTERN HOLDER ALSO SHOWN

DRAWN BY **WWM**

DATE 9-11-08

DWG. NO. **AI-1742**