



Model M-32/17 Wheelchair Accessible Firering
(Note: anchor pins not used in this installation)

- **Flanged firering for strength and safety**
- **Four cooking height levels with easy grate adjustment in slots die-cut from the steel heat panels**
- **Cooking grate adjustment and height conform to ADA guidelines**
- **Public use-type spring grips of coiled steel bar**
- **Anchor pins provided to permanently locate firering**
- **“Bottomless” design with aggregate fill installs on any surface**
- **Recommended aggregate fill raises fire to working height that conforms with ADA guidelines**
- **Utility shelf option**

AVAILABLE OPTIONS

Utility Shelf
Heat Shield

SPECIFICATIONS:

- **Model M-32/17/PA** has a 32" overall dia., 16-3/8" high, “D” shaped firering constructed from 3/16" thick steel with a formed (NOT WELDED) 1" flanged lip around the top of the ring and die-formed flange at top of a 20" flat area behind the grate. Ten 9/16" dia. drain/draft/anchor holes are located around the perimeter.
 - 300 sq. in. cooking grate is constructed from 1/2" dia. A-36 steel bar with grate bars on 1-1/8" centers with a one-piece wrap-around perimeter bar with formed corners. Grate is securely welded to two 5/8" dia. steel support bars made to adjust to four heights from 19" to 24" above ground level in die punched vertical slots with two substantially constructed spring grips suitable for public use made from 1/8" x 1/2" flat bar (not wire springs).
 - Overall unit height is 25-3/8". Unit is designed to allow reasonably easy access to the cooking grate from a wheelchair.
 - Firering is designed to be filled with customer supplied aggregate fill to a level 10-3/8" above ground level to raise fire to proper height and protect hard surfaces from heat damage. This level conforms with ADA guidelines of a minimum of 9" of fill above ground level.
 - Unit is provided with three 1/2" dia. anchor pins for concrete embedment (indicated by /PA in model no., e.g. M-32/17/PA).
 - Entire unit is finished in high temperature, heat resistant, nontoxic black enamel.
 - **Optional:** Firering is provided with a 3/16" x 7-1/8" x 9-5/8" steel plate utility shelf. (Add /S to model no., e.g. M-32/17/PA/S.)
 - **Optional:** Firering is provided with an 8" high heat shield constructed from 10 ga. steel welded on to new firerings. Heat shield provides a 7/8" cooling air gap around the area of the firering exposed to the fire (Add /H to model no., e.g. M-32/17/PA/H.)
- Note: The optional utility shelf fits both firering and optional heat shield. (When ordering both options, add /H/S to model no., e.g. MA-32/17/PA/H/S.)

RJ Thomas Mfg. Co., Inc.

PO Box 946 • Cherokee, IA 51012-0946 • PH: 712-225-5115 • 800-762-5002 • FAX: 712-225-5796
E-mail: pilotrock@rjthomas.com • Web Site: <http://www.pilotrock.com>

© 2017 RJ Thomas Mfg. Co., Inc. PILOT ROCK® Park Products is a registered trademark of RJ Thomas Mfg. Co., Inc.

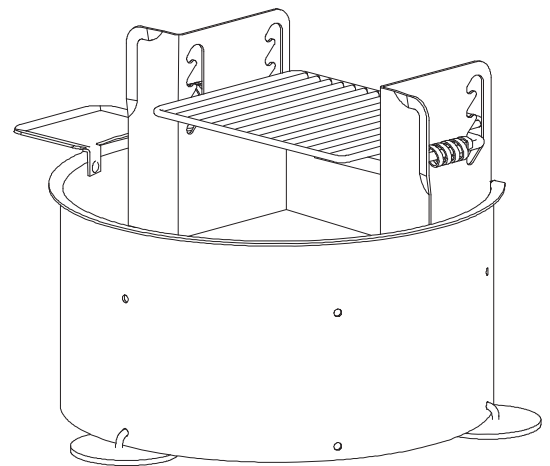
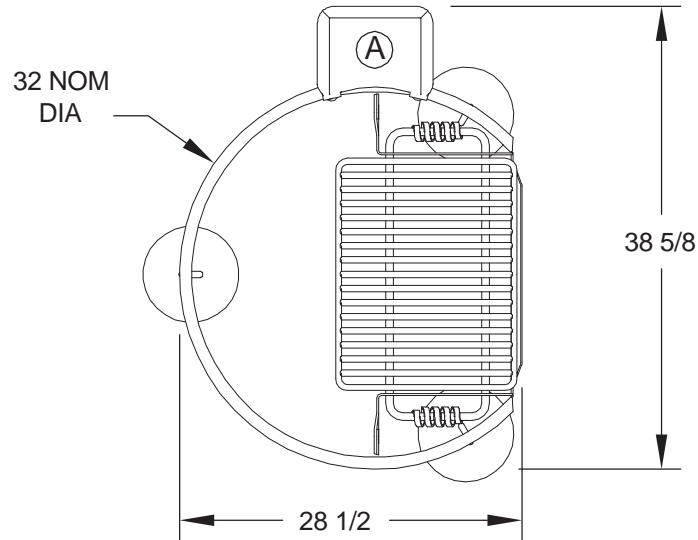

(A) OPTIONAL UTILITY SHELF - ADD /S TO MODEL NUMBER

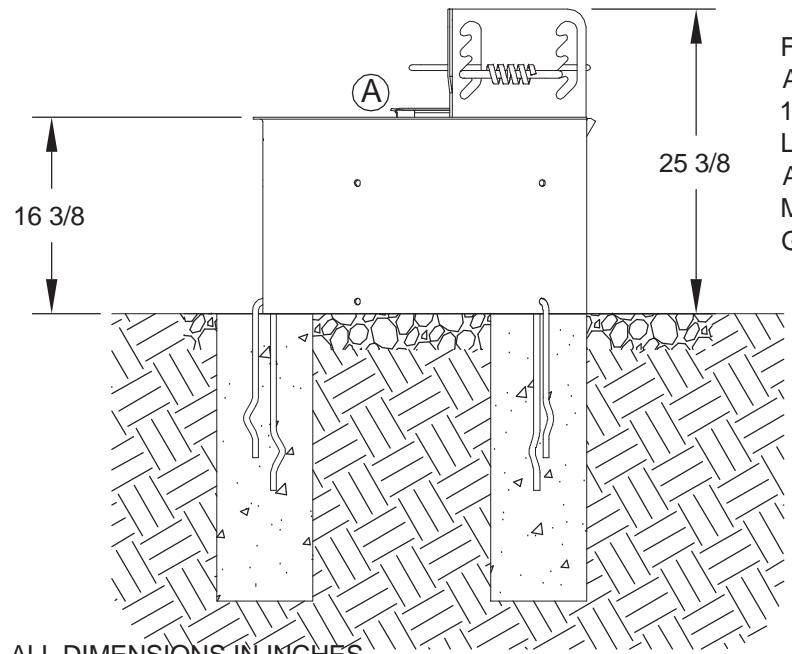

FILL WITH COARSE AGGREGATE FILL TO 10-3/8" ABOVE GROUND LEVEL (CONFORMS TO ADA GUIDELINES OF MIN 9" HEIGHT ABOVE GROUND FOR FIRE BASE)

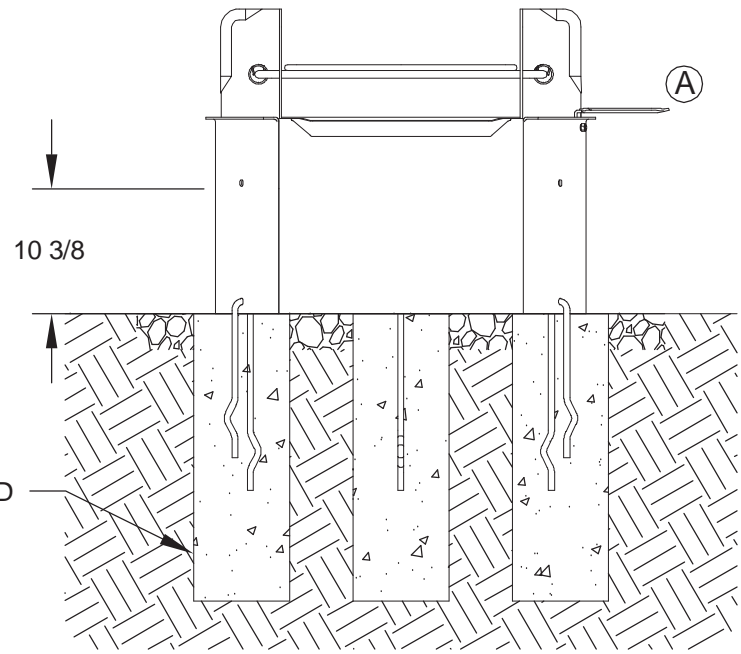

8" DIA X 24" DEEP (18" MIN) CONCRETE FOOTING RECOMMENDED

ALL DIMENSIONS IN INCHES

RJThomas Mfg. Co., Inc.
P.O. Box 946 • Cherokee, IA 51012-0946

DRAWN BY
WWM

TITLE **M-32/17/PA MULTI-LEVEL WHEELCHAIR ACCESSIBLE FIRERING WITH PIN ANCHORS**
-SHOWN WITH OPTIONAL UTILITY SHELF

DATE **10-08-08**

DWG. NO. **AI-1410**