



Model MST/P/CB-1SP/TN, Marksman Shooting Table with surface-mount base plate, black powder coated frames, shown with optional solid steel plate top/seats thermo-coated in green.

The swivel seat accommodates both left- and right-handed users.



- **Quality construction throughout**
- **Frames are hot-dip galvanized after fabrication for superior corrosion resistance**
- **Thermo-plastic Coating heat fused to Perforated Steel Top and Seats for durability**
- **Thermo-plastic Coating formulated with U.V. stabilizers for ultraviolet protection**

AVAILABLE OPTIONS

Powder Coat Finish in choice of colors for steel frame components
Choice of colors of Thermo-plastic Coating Perforated Steel or Solid Steel Plate

SPECIFICATIONS:

- A durable marksman table for outdoor shooting ranges and gun clubs, designed by experienced marksmen.
- **Model MST/P-1R** includes welded on base plates on each frame leg for a surface mount/bolt down installation. The welded on base plates are 1/4 in. x 8 in. x 8 in. square with (4) 25/32 in. diameter holes. Anchor bolts not included.
- The twin radius-cut table top design and the swivel seat are designed to accommodate left- and right-handed shooters.
- **Top Dimensions:** Table top is 34 in. wide by 48 in. deep. Installed height is 38 in. to top of table (all dimensions nominal).
- **Seat Dimensions:** Swivel seat is 16 in. diameter. Once installed on the support post the swivel seat cannot be removed. The seat offers six 1-inch height adjustment options from 20-1/4 in. to 25-1/4 in. (nom.) using a locking pin.
- The top is supported by a tripod using two 2-3/8 in. OD steel pipe posts and one 3-1/2 in. OD post. The swivel seat is installed on the 3-1/2 in. post. The swivel seat arm is a welded assembly of 7 ga. steel and 4-inch OD steel tube.
- **Standard:** Table top and swivel seat are fabricated using 14 ga. perforated steel with 2-1/2 in. wide edge band with supporting 14 ga. reinforcements. Mounting brackets are formed using 7 ga. steel.
- **Standard:** All steel frame components are hot-dip galvanized after fabrication to ASTM-A123 to maintain an average zinc coating of 2.0 oz. per sq. ft. of surface area (indicated by “/G” in model no., e.g. MST/P/G-1RW).
- **Standard:** All steel surfaces of the top are covered with a thermo-plastic coating in a Brown color (indicated by “RW” in model no., e.g. MST/P/G-1RW). The UV-stabilized thermo-plastic coating is applied in a multi step process of material preparation and finish application designed to permanently heat fuse and bond the finish to the steel. The thermo-plastic polyethylene finish is impact resistant, does not support mold or mildew, and the textured matte surface is less susceptible to marring and scuffing.
- **Optional:** Table top and swivel seat are fabricated using 16 ga. solid steel plate with 2-1/2 in. wide edge band with supporting 16 ga. reinforcements. Mounting brackets are formed using 7 ga. steel.
- **Optional:** Surface Mount Anchor Kit (#ANC5-4) not included. Use one kit per post.
- **Optional:** Color choices of powder coated steel frame components. See Specification Bulletin #SPC-CO-001.
- **Optional:** Top/Seat color choices of Thermo-plastic coated steel components. For optional colors choices see Specification Bulletin #SPC-CO-001.

RJ Thomas Mfg. Co., Inc.

PO Box 946 • Cherokee, IA 51012-0946 • PH: 712-225-5115 • 800-762-5002 • FAX: 712-225-5796
E-mail: customerservice@rjthomas.com • Web Site: <https://www.pilotrock.com>

© 2026 RJ Thomas Mfg. Co., Inc. PILOT ROCK® Park Products is a registered trademark of RJ Thomas Mfg. Co., Inc.

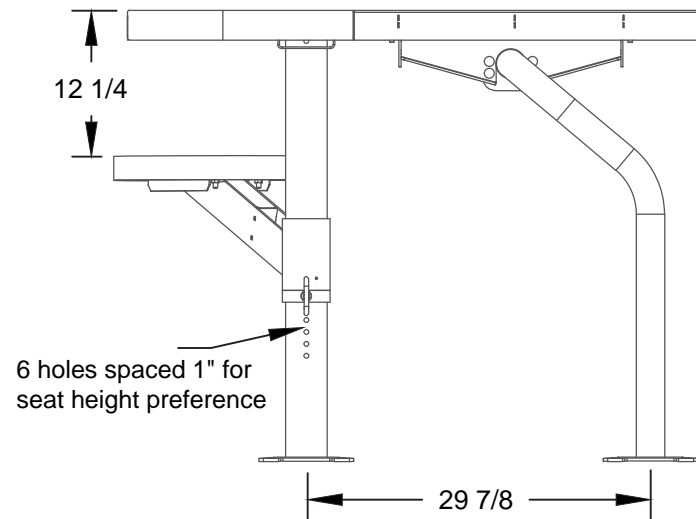
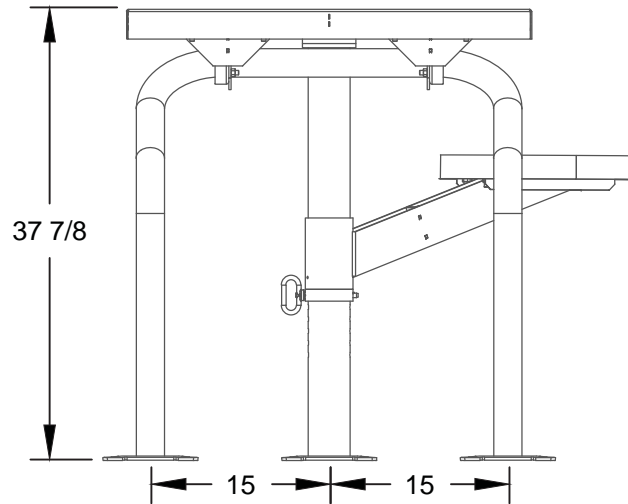
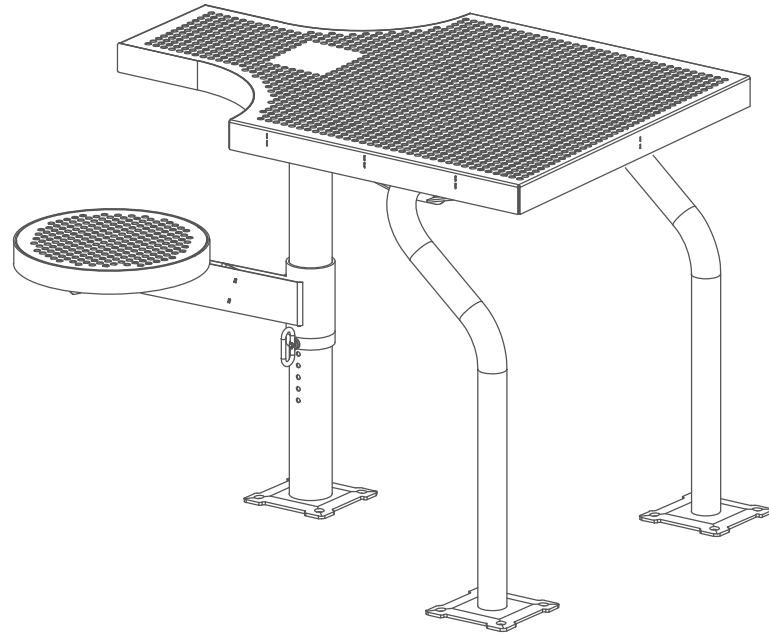
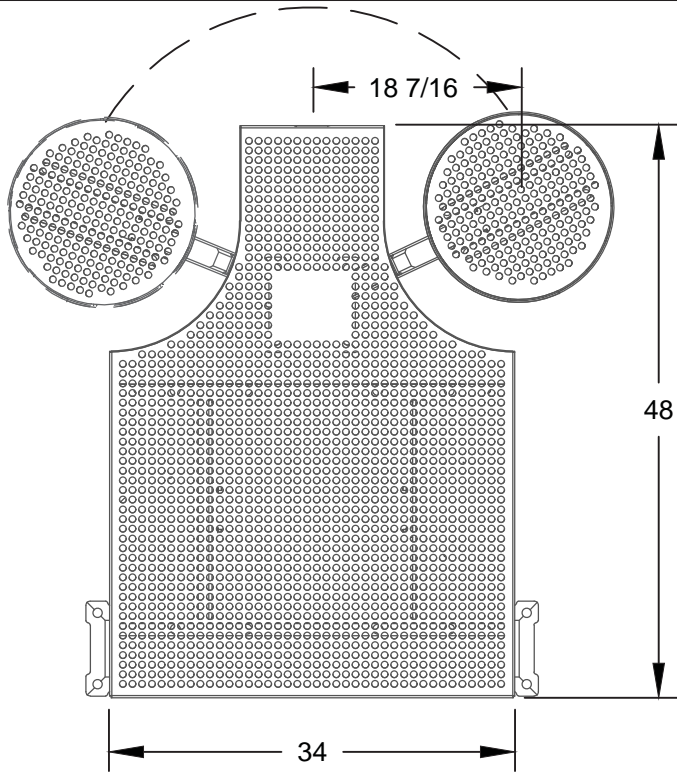

ALL DIMENSIONS IN INCHES

RJThomas Mfg. Co., Inc.
P.O. Box 946 • Cherokee, IA 51012-0946

DRAWN BY
JGJ

TITLE
MST/P-1 SERIES Marksman Shooting Table with perforated steel top and seats, shown with surface mount base plates 1/2".

DATE 04-28-2026

DWG. NO. AI-3053