

**Model PCXB Portable or Surface Mount
10 Ft. Bench with H-Type Thermo-plastic
Coated Perforated Steel Back and Seat**

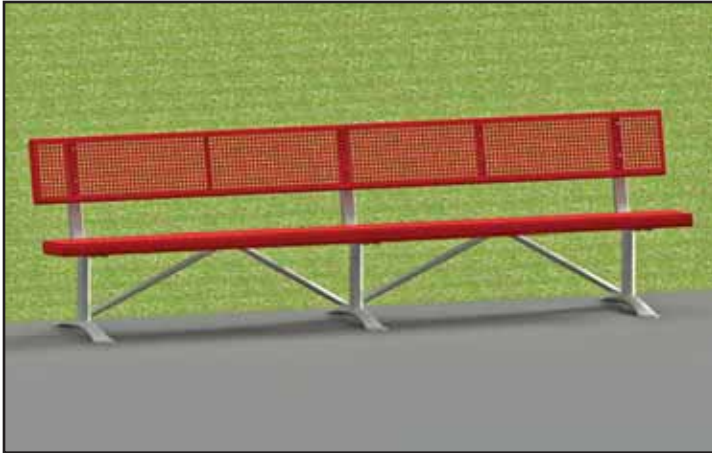

Model PCXB3/G-10HR10 Portable/Surface Mount Bench with hot-dip galvanized frames, 10 Ft. long with 10" wide red H-Type thermo-plastic coated perforated steel seat and back.

- **Extra heavy design to be stronger and more stable with a simple, clean style**
- **Sturdy, formed and welded steel frame construction**
- **Frames are Hot-Dip Galvanized after fabrication for superior corrosion resistance**
- **Thermo-plastic Coating heat fused to Perforated Steel Back and Seat for durability**
- **Thermo-plastic Coating formulated with U.V. stabilizers for ultraviolet protection**
- **Quality construction throughout**

AVAILABLE OPTIONS

- **Powder Coat Finish in choice of colors for steel frame components**
- **Choice of colors of Thermo-plastic Coating**
- **10" or 12" seat and back width**
- **Custom Lettering available (call for details)**
- **Armrests**

SPECIFICATIONS:

- **Model PCXB** end frames are one-piece, welded construction with a back and seat bracket of 2-3/8" x 1-1/2" x 1/8" nominal sized, die-formed channel, and a 2.375" (2-3/8") O.D. post and foot to meet 2" nominal steel pipe size specifications. Frame foot is formed with flattened and rounded ends. A 9/16" hole is provided in each end of foot for optional surface mounting with concrete anchors (anchors not included).
- **Model PCXB3/G-10** is 10 ft. long (nom.) with three frames and diagonal braces.
- **Standard:** All steel frame components are hot-dip galvanized after fabrication to ASTM-A123 to maintain an average zinc coating of 2.0 oz. per sq. ft. of surface area (indicated by "/G" in model no., e.g. PCXB3/G-10HW10).
- **H-Type** seat and back are each a one-piece welded construction, fabricated from a 14 ga. perforated steel surface with 9/16" dia. holes in a 13/16" center to center in-line pattern and 2-1/2" x 10 ga. roll-formed vertical edges on all sides reinforced by a 10 ga. die-formed angle substructure. Substructure includes all mounting holes for easy assembly of bench.
- **Standard:** All steel surfaces of the seat and back are covered with a thermo-plastic coating in a Brown color (indicated by "HW" in model no., e.g. PCXB3/G-10HW10). The UV-stabilized thermo-plastic coating is applied in a multi step process of material preparation and finish application designed to permanently heat fuse and bond the finish to the steel. The thermo-plastic polyethylene finish is impact resistant, does not support mold or mildew, and the textured matte surface is less susceptible to marring and scuffing.
- All fasteners are provided for assembly.
- **Optional:** Rubber bumper foot pads available to protect and prevent the steel frame foot from coming in contact with hard surface floorings. Each Model PCXB3 bench requires three sets of 2 foot pads (**BFP1-2**).
- **Optional:** Color choices of powder coated steel frame components. For optional colors choices see Specification Bulletin #SPC-CO-001.
- **Optional:** Color choices of Thermo-plastic coated steel components. For optional colors choices see Specification Bulletin #SPC-CO-001.
- **Optional:** Seat and back are each a 10" wide one-piece welded construction with 10 ga. x 2-1/2" (2" on 4 ft. models) roll-formed vertical edges on all sides. Indicate choice by changing "10" in model no. to "12", e.g. PCXB3/G-10HW12.

RJ Thomas Mfg. Co., Inc.

PO Box 946 • Cherokee, IA 51012-0946 • PH: 712-225-5115 • 800-762-5002 • FAX: 712-225-5796
E-mail: customerservice@rjthomas.com • Web Site: <https://www.pilotrock.com>

© 2026 RJ Thomas Mfg. Co., Inc. PILOT ROCK® Park Products is a registered trademark of RJ Thomas Mfg. Co., Inc.

MODEL NUMBER	DIMENSION		
	a	b	c
PCXB3-10-10	10	10	34 7/8
PCXB3-10-12	12	12	35 7/8

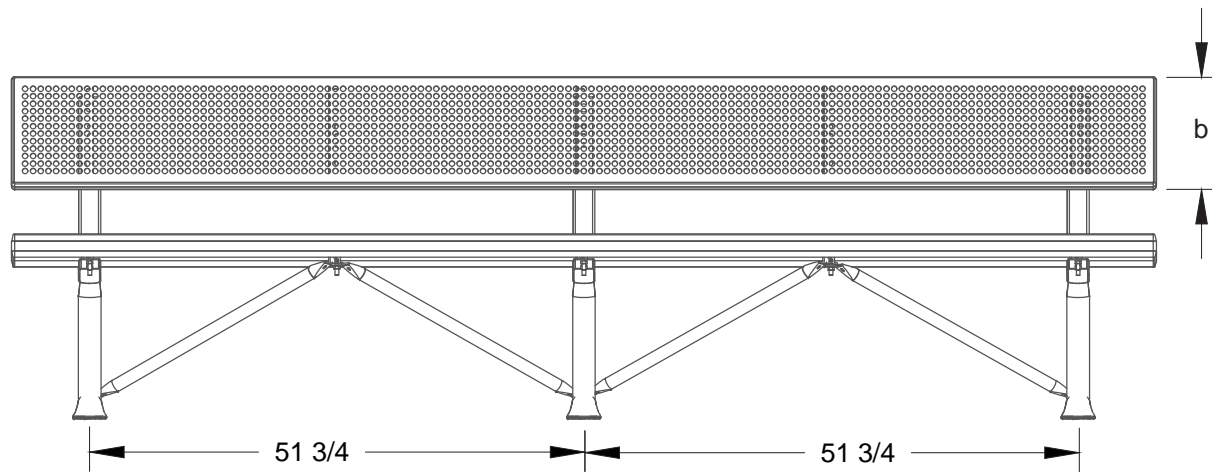
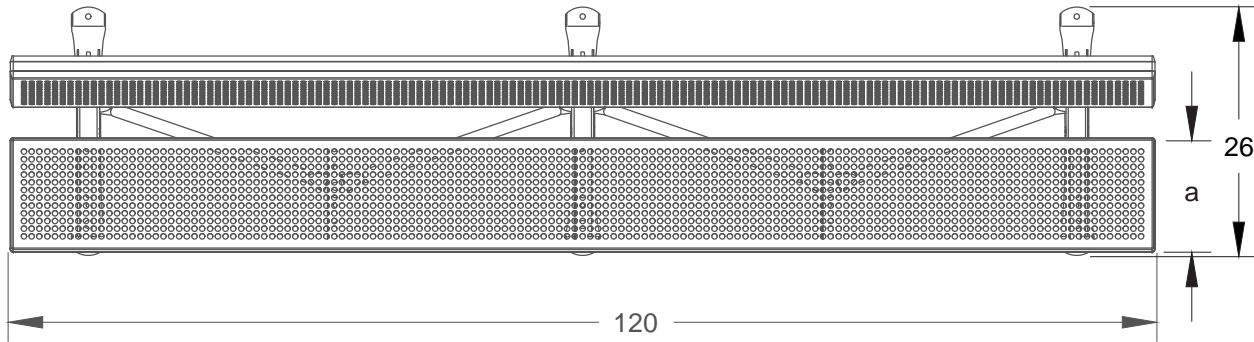
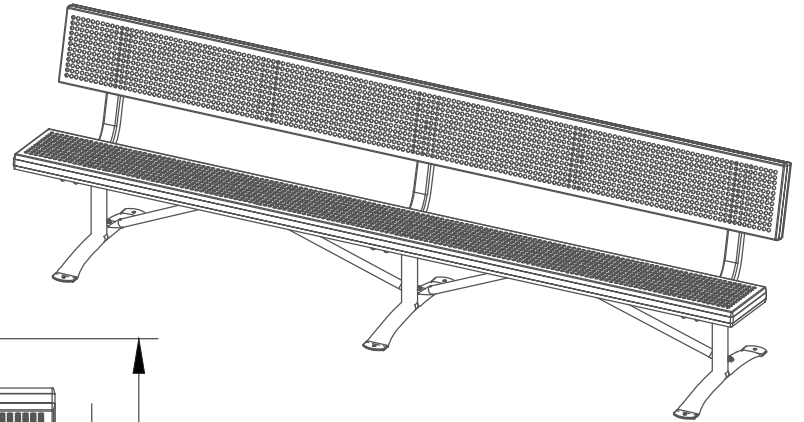

*CENTER TO CENTER OF MOUNTING HOLES

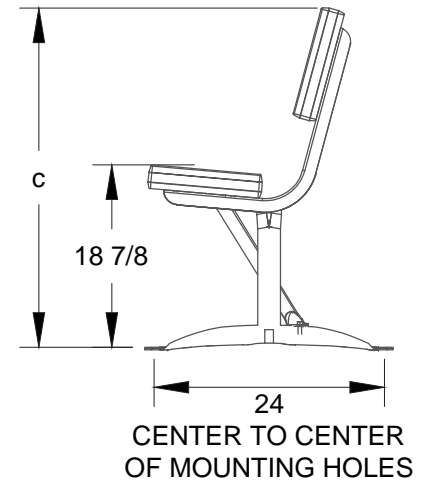

ALL DIMENSIONS IN INCHES

RJThomas Mfg. Co., Inc.
P.O. Box 946 • Cherokee, IA 51012-0946

DRAWN BY
JGJ

TITLE
MODEL PCXB EXTRA HEAVY DUTY 10 FOOT PORTABLE/SURFACE MOUNT BENCH
WITH H-TYPE THERMO-PLASTIC COATED PERFORATED STEEL SEAT AND BACK

DATE 04-17-2026

DWG. NO. AI-3080