



*Model PCXB/G-8VI12 Surface Mount Bench
with hot-dip galvanized frames, 8 ft. long with 12" (nom.) wide
gray V-Type thermo-plastic coated expanded steel seat and back.*

- **Extra heavy design to be stronger and more stable with a simple, clean style**
- **Sturdy, formed and welded steel frame construction**
- **Frames are Hot-Dip Galvanized after fabrication for superior corrosion resistance**
- **Thermo-plastic Coating heat fused to Expanded Steel Back and Seat for durability**
- **Thermo-plastic Coating formulated with U.V. stabilizers for ultraviolet protection**
- **Quality construction throughout**

AVAILABLE OPTIONS

- 4', 6', or 8' models
- Powder Coat Finish in choice of colors for steel frame components
- Choice of colors of Thermo-plastic Coating
- 10" or 12" seat and back width
- Armrests

SPECIFICATIONS:

- **Model PCXB** end frames are one-piece, welded construction with a back and seat bracket of 2-3/8" x 1-1/2" x 1/8" nominal sized, die-formed channel, and a 2.375" (2-3/8") O.D. post and foot to meet 2" nominal steel pipe size specifications. Frame foot is formed with flattened and rounded ends. A 9/16" hole is provided in each end of foot for optional surface mounting with concrete anchors (anchors not included).
- **Model PCXB/G-4** is 4 ft. long (nom.).
- **Model PCXB/G-6** is 6 ft. long (nom.) with diagonal braces.
- **Model PCXB/G-8** is 8 ft. long (nom.) with diagonal braces.
- **Standard:** All steel frame components are hot-dip galvanized after fabrication to ASTM-A123 to maintain an average zinc coating of 2.0 oz. per sq. ft. of surface area (indicated by "/G" in model no., e.g. PCXB/G-4VW10).
- **V-Type** seat and back are each a one-piece welded construction, fabricated from a 3/4-#9 expanded steel surface with 10 ga. x 2-1/2" roll-formed vertical edges on all sides and reinforced by a 10 ga. die-formed angle substructure. Substructure includes all mounting holes for easy assembly of bench.
- **Standard:** All steel surfaces of the seat and back are covered with a thermo-plastic coating in a Brown color (indicated by "VW" in model no., e.g. PCXB/G-4VW10). The UV-stabilized thermo-plastic coating is applied in a multi step process of material preparation and finish application designed to permanently heat fuse and bond the finish to the steel. The thermo-plastic polyethylene finish is impact resistant, does not support mold or mildew, and the textured matte surface is less susceptible to marring and scuffing.
- All fasteners are provided for assembly.
- **Optional:** Color choices of powder coated steel frame components. For optional colors choices see Specification Bulletin #SPC-CO-001.
- **Optional:** Color choices of Thermo-plastic coated steel components. For optional colors choices see Specification Bulletin #SPC-CO-001.
- **Optional:** Seat and back are each a 12" wide one-piece welded construction with 10 ga. x 2-1/2" roll-formed vertical edges on all sides. Indicate choice by changing "10" in model no. to "12", e.g. PCXB/G-4VW12.

RJ Thomas Mfg. Co., Inc.

PO Box 946 • Cherokee, IA 51012-0946 • PH: 712-225-5115 • 800-762-5002 • FAX: 712-225-5796
E-mail: pilotrock@rjthomas.com • Web Site: <http://www.pilotrock.com>

© 2012 RJ Thomas Mfg. Co., Inc. PILOT ROCK® Park Products is a registered trademark of RJ Thomas Mfg. Co., Inc.

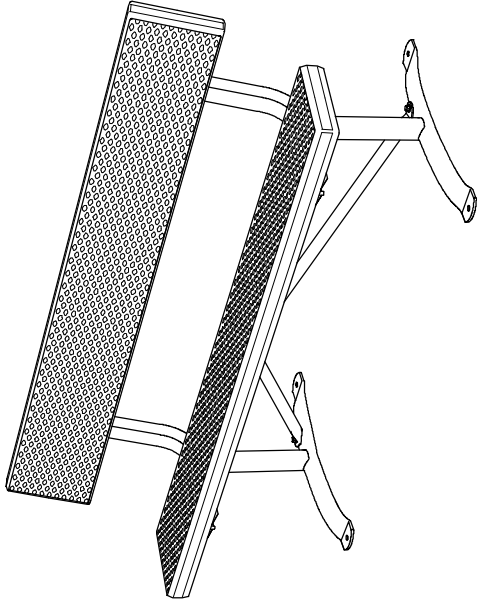
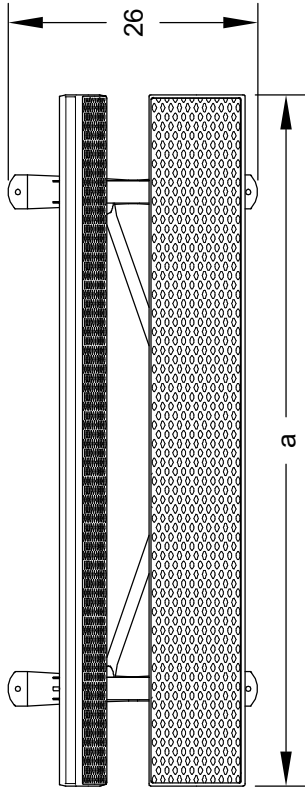

MODEL NUMBER	DIMENSION		
	a	b	c
PCXB-4-10	44	30	35
PCXB-6-10	72	51-3/4	35
PCXB-8-10	96	70	35
PCXB-4-12	48	36	36
PCXB-6-12	72	51-3/4	36
PCXB-8-12	96	70	36

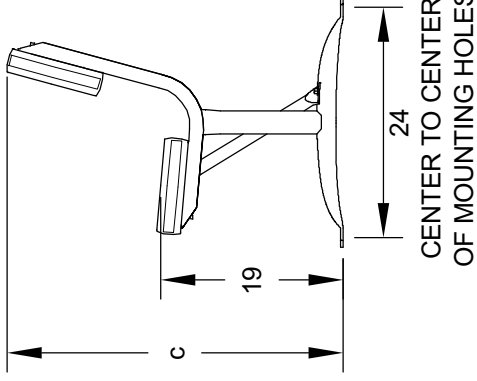
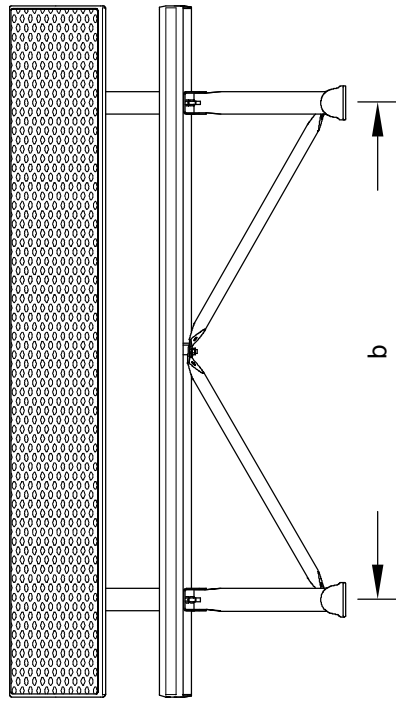

ALL DIMENSIONS IN INCHES

RJ Thomas Mfg. Co., Inc.
 P.O. Box 946 • Cherokee, IA 51012-0946

DRAWN BY
WWM

TITLE MODEL PCXB EXTRA HEAVY DUTY 4, 6 AND 8 FOOT PORTABLE/SURFACE MOUNT BENCH WITH V-TYPE THERMO-PLASTIC COATED EXPANDED STEEL SEAT AND BACK

DATE 5-11-11
 DWG. NO. **AI-1642**