



Model PQT3/CB-4AL 48" Square Top, Wheelchair Accessible, Embedded Mount Table with Black Powder Coated Frame and Aluminum Top and Seat Planks

- **Three seats and one open side for wheelchair access**
- **Square design optimizes table top usage and creates a more intimate setting**
- **Square table fits into more compact areas**
- **Permanent embedded mounting**
- **Sturdy 5-3/8" square center pedestal, 3-1/2" diameter round radial seat supports**
- **Frames are hot dip galvanized after fabrication for superior corrosion resistance**
- **Seats and Top are Aluminum with a clear anodized maintenance-free finish**
- **Quality construction throughout**

AVAILABLE OPTIONS

- **Powder Coat Finish in choice of colors for steel frame components**
- **Powder Coat Finish in choice of colors for aluminum top and seats**
- **Umbrella**
- **Surface mount base plate**

SPECIFICATIONS:

- **Model PQT3-4** table frame incorporates a 5-3/8" square single pedestal post designed to embed into a concrete footing.
- Three seat support frames are each a one-piece welded construction of 3-1/2" dia. x 11 ga. wall structural steel tubing, a 2-3/8" dia. 10 ga. wall tube, and 2" x 2" x 1/8" die formed steel angles designed to resist lateral torsion and deflection when loaded.
- **Model PQT3-4** tables have been adapted for wheelchair accessibility. By removing one or more arm/seat structures the side of the table is opened to provide wheelchair access.
- Frame is designed in a theft-proof manner with all fasteners extending into the post to prevent removal after assembly.
- **Model PQT3-4** has a 48" (nom) square table top.
- Table height is 32-1/4" (nom). Seat height is 20-3/8" (nom).
- All galvanized fasteners are provided for table assembly.
- **Standard:** All steel frame components are hot-dip galvanized after fabrication to ASTM-A123 to maintain an average zinc coating of 2.0 oz. per sq. ft. of surface area (indicated by "/G" in model no., e.g. PQT3/G-4AL).
- Aluminum is extruded 6063-T6 aluminum alloy in planks with dimensions equivalent to that of 2" x 10" nominal sized lumber. The plank design is 1-3/4" x 9-5/8" with four structural reinforcement ribs for greater rigidity. Aluminum planks are provided with a clear anodized finish as per anodizing specification 204 R1. Aluminum clips to fasten planks to frames are included.
- Channel end caps are of extruded 6063-T6 aluminum alloy provided with a clear anodized finish as per anodizing specification 204 R1. End caps are press fitted over ends of aluminum planks and mechanically fastened in place at the factory.
- Table tops are assembled into single units at the factory with one-piece end caps across each end.
- **Optional:** All steel frame components have powder coat finish. For color choices see Specification Bulletin #SPC-CO-001.
- **Optional:** Aluminum top and seat planks and end caps have powder coat finish. For color choices see Specification Bulletin #SPC-CO-001.
- **Optional:** Table is provided with umbrella holes in table tops and cup and collar sets for mounting umbrellas. To specify, add "/U" to the end of the model no., e.g. PQT3/G-3AL/U.
- **Optional:** Frame is provided with a 3/8" x 15-3/4" x 15-3/4" steel base plate to bolt table to existing concrete pad. To specify add "/P" after the "PQT" in the model no., e.g. PQT3/P/G-4AL. (Anchor bolts not included.)

RJ Thomas Mfg. Co., Inc.

PO Box 946 • Cherokee, IA 51012-0946 • PH: 712-225-5115 • 800-762-5002 • FAX: 712-225-5796
E-mail: pilotrock@rjthomas.com • Web Site: <https://www.pilotrock.com>

© 2021 RJ Thomas Mfg. Co., Inc. PILOT ROCK® Park Products is a registered trademark of RJ Thomas Mfg. Co., Inc.

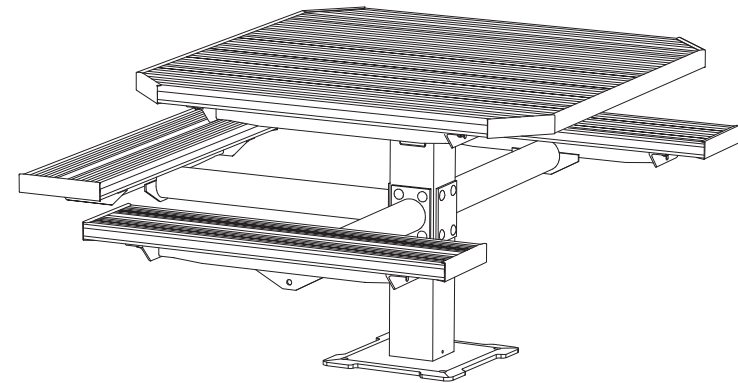
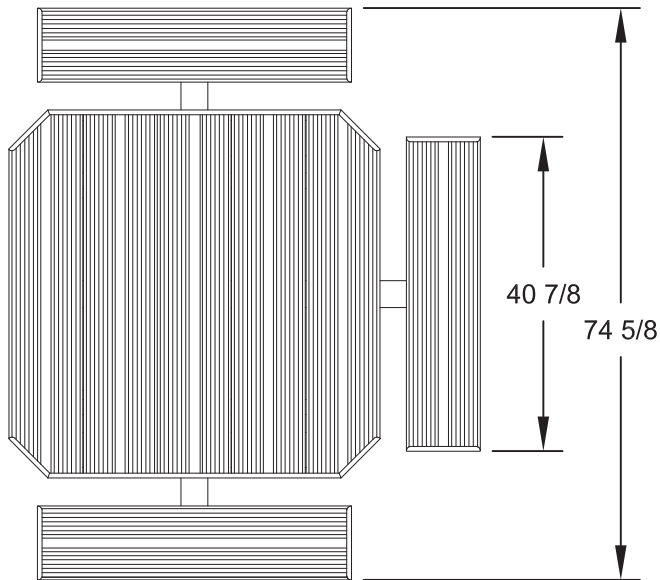

Shown with Optional Surface Mount Base Plate (P)

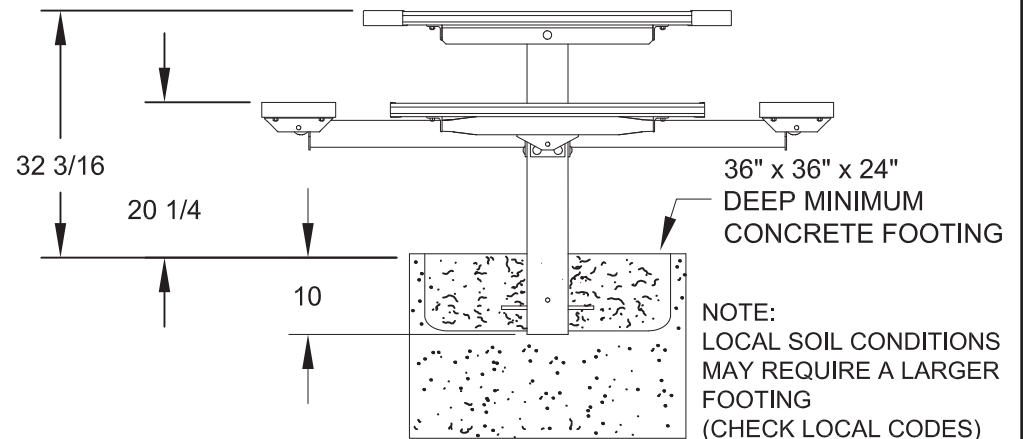
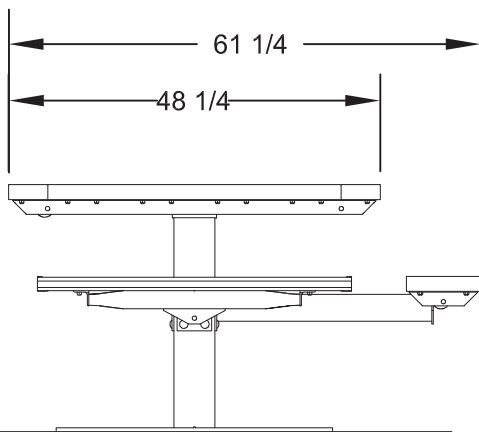

ALL DIMENSIONS IN INCHES

ALL DIMENSIONS IN INCHES

RJThomas Mfg. Co., Inc.
P.O. Box 946 • Cherokee, IA 51012-0946

DRAWN BY
JGJ

TITLE **PQT3 SERIES 4 FOOT EMBEDDED MOUNT SQUARE WHEELCHAIR ACCESSIBLE
SINGLE PEDESTAL TABLE WITH ALUMINUM TOP AND SEAT PLANKS**

DATE 04-19-21

DWG. NO. **AI-1697A**