

*Model PQT/G-4UP 5 Plank, 48" Square Top, Embedded Mount Table
with Hot dip Galvanized Frame
and Untreated Southern Yellow Pine Planks*

- **Square design optimizes table top usage and creates a more intimate setting**
- **Square table fits into more compact areas**
- **Permanent embedded mounting**
- **Sturdy 5-3/8" square center pedestal, 3-1/2" diameter round radial seat supports**
- **Precision drilled, Untreated #1 Southern Yellow Pine Seat and Top Planks**
- **Quality construction throughout**

AVAILABLE OPTIONS

3' or 4' square models

Powder Coat Finish in choice of colors for steel frame components

Pressure treated #1 Southern Yellow Pine lumber (Cedar, Fir, or Redwood lumber when in stock)

Choice of two Umbrella styles with mounting hardware

Surface mount base plate

SPECIFICATIONS:

- **PQT Series** table frame incorporates a 5-3/8" square single center pedestal post designed to be embedded in a concrete footing.
- Four seat support frames are each a one-piece welded construction of 3-1/2" dia. x 11 ga. wall structural steel tubing, a 2-3/8" dia. 10 ga. wall tube, and 2" x 2" x 1/8" die formed steel angles designed to resist lateral torsion and deflection when loaded.
- Frame is assembled in a theft-proof manner with all fasteners extending into the central post to prevent removal once the table is assembled.
- **Model PQT/G-3UP** has a nominal 38" square table top utilizing (4) top planks.
- **Model PQT/G-4UP** has a nominal 48" square table top utilizing (5) top planks.
- Nominal table height is 31-13/16". Nominal seat height shall be 19-7/8".
- Top planks are supported by a subframe of 2" x 2" x 1/8" die formed steel angle, 10 ga. steel channel, and 2-3/8" round tubing.
- All galvanized fasteners are provided for table assembly.
- **Standard:** All frame components are hot-dip galvanized after fabrication to ASTM-A123 to maintain an average zinc coating of 2.0 oz. per sq. ft. of surface area (indicated by "/G" in model no., e.g. PQT/G-3UP).
- **Standard:** Lumber is Untreated #1 grade Southern Yellow Pine (indicated by "UP" in model no., e.g. PQT/G-3UP) 2" x 10" nominal sized planks, kiln dried to reduce moisture content. All lumber is precision drilled to facilitate assembly and has all exposed edges removed to a 3/8" radius.
- **Optional:** Treated #1 Southern Yellow Pine is readily available and is pressure treated (KDAT) to preserve wood against decay. To specify, change "UP" in model no. to "TP", e.g. PQT/G-4TP. (Cedar, Fir and Redwood are available when in stock –please inquire.)
- **Optional:** Color choices of powder coated steel frame components. For optional colors choices see Specification Bulletin #SPC-CO-001.
- **Optional:** Tables is provided with umbrella holes in table tops and cup and collar sets for mounting umbrellas. To specify, add "/U" to the end of the model no., e.g. PQT/G-3UP/U.
- **Optional:** Frame is provided with a 3/8" x 15-3/4" x 15-3/4" steel base plate to bolt table to existing concrete pad. To specify add "/P" after the PQT in the model no., e.g. PQT/P/G-4UP. (Anchor bolts not included.)

RJ Thomas Mfg. Co., Inc.

PO Box 946 • Cherokee, IA 51012-0946 • PH: 712-225-5115 • 800-762-5002 • FAX: 712-225-5796
E-mail: pilotrock@rjthomas.com • Web Site: <http://www.pilotrock.com>

© 2017 RJ Thomas Mfg. Co., Inc. PILOT ROCK® Park Products is a registered trademark of RJ Thomas Mfg. Co., Inc.

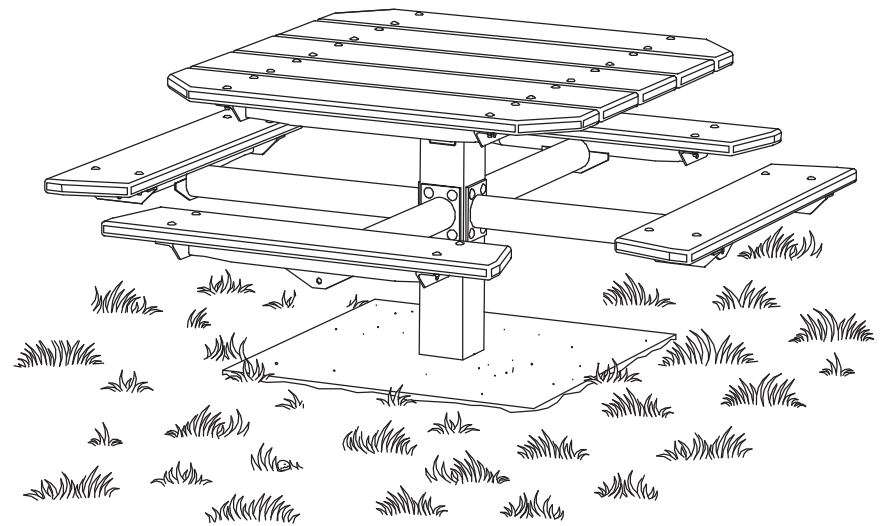
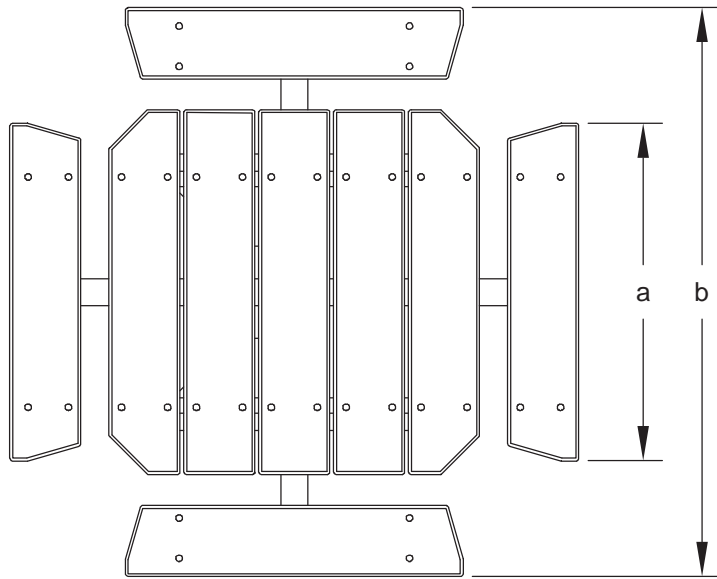

MODEL NUMBER	DIMENSION	
	a	b
PQT-3	33 3/8	68
PQT-4	44	74

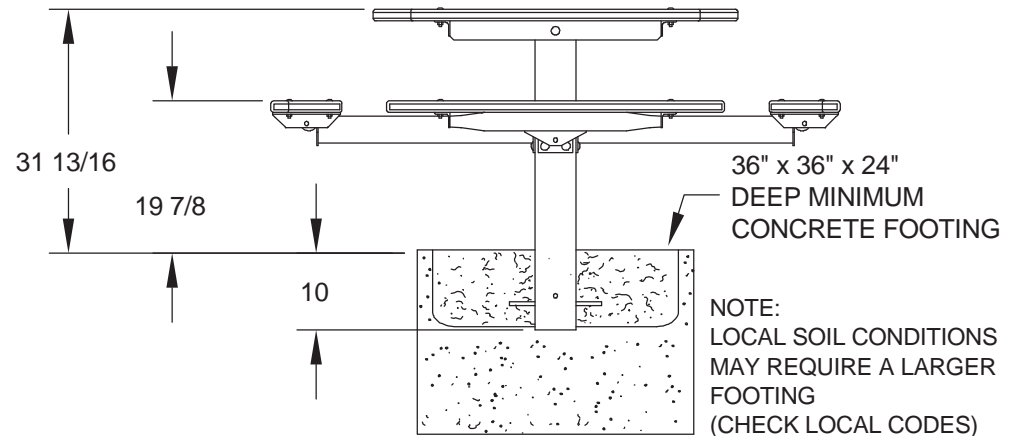
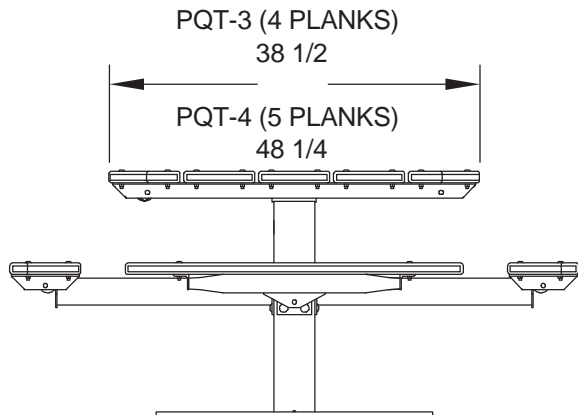

ALL DIMENSIONS IN INCHES

RJThomas Mfg. Co., Inc.
P.O. Box 946 • Cherokee, IA 51012-0946

DRAWN BY
WWM

TITLE **PQT SERIES 3 AND 4 FOOT EMBEDDED MOUNT SQUARE SINGLE PEDESTAL TABLE WITH LUMBER TOP AND SEAT PLANKS**

DATE 10-31-08

DWG. NO. **AI-1695**