

PQT Series Pedestal Square Table with V-Type Thermo-plastic Coated Expanded Steel Top and Seats

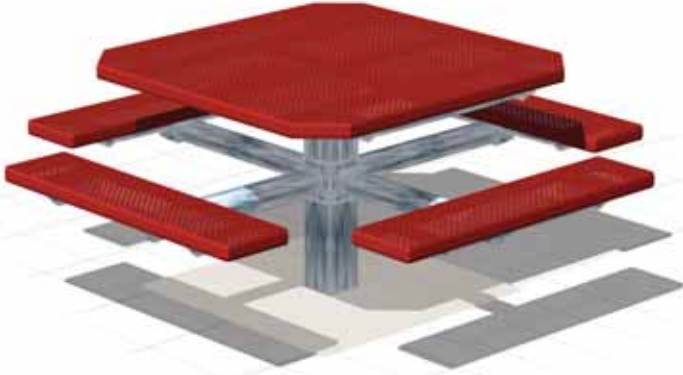

Model PQT/G-4VR 48" Square Top, Embedded Mount Table with hot dip galvanized frame and red V-Type thermo-plastic coated expanded steel top and seats

- **Square design optimizes table top usage and creates a more intimate setting**
- **Square table fits into more compact areas**
- **Permanent embedded mounting**
- **Sturdy 6" square center pedestal, 3-1/2" diameter round radial seat supports**
- **Thermo-plastic Coating heat fused to Expanded Steel Top and Seats for durability**
- **Thermo-plastic Coating formulated with U.V. stabilizers for ultraviolet protection**
- **Quality construction throughout**

AVAILABLE OPTIONS

- **Powder Coat Finish in choice of colors for steel frame components**
- **Choice of colors of Thermo-plastic Coating**
- **Umbrella**
- **Surface mount base plate**
- **Contour Bench Seats**

SPECIFICATIONS:

- **PQT Series** table frame has a 6" square single center pedestal post designed to embed into a concrete footing.
- Four seat support frames are each a one-piece welded construction of 3-1/2" dia. x 11 ga. wall structural steel tubing, a 2-3/8" dia. 10 ga. wall tube, and 2" x 2" x 1/8" die formed steel angles designed to resist lateral torsion and deflection when loaded.
- Frame is designed in a theft-proof manner with all fasteners extending inside post to prevent removal after assembly.
- **Model PQT/G-4** has a 48" (nom) square table top.
- Table height is 32-1/4" (nom). Seat height is 20-3/8" (nom).
- Table top is supported by a subframe of 2" x 2" x 1/8" die formed steel angle, 10 ga. steel channel, and 2-3/8" round tubing.
- All galvanized fasteners are provided for table assembly.
- **Standard:** All frame components are hot-dip galvanized after fabrication to ASTM-A123 to maintain an average zinc coating of 2.0 oz. per sq. ft. of surface area (indicated by "/G" in model no., e.g. PQT/G-4VW).
- **V-Type** table top and seats are each a one-piece welded construction, fabricated from a 3/4"-#9 expanded steel surface with 10 ga. x 2-1/2" roll-formed vertical edges on all sides and reinforced by a 10 ga. die-formed angle substructure. Substructure includes all mounting holes for easy assembly of table.
- **Standard:** All steel surfaces of the top and seats are covered with a thermo-plastic coating in a Brown color (indicated by "VW" in model no., e.g. PQT/G-4VW). The UV-stabilized thermo-plastic coating is applied in a multi step process of material preparation and finish application designed to permanently heat fuse and bond the finish to the steel. The thermo-plastic polyethylene finish is impact resistant, does not support mold or mildew, and the textured matte surface is less susceptible to marring and scuffing.
- **Standard:** Table is provided with cup and collar sets for mounting an umbrella.
- **Optional:** Table is provided with four 45" long contoured bench seats constructed of thermo-plastic coated steel frame and expanded steel seat. To specify add "B" after the PQT in the model no., e.g. PQT/G-4VWB.
- **Optional:** Color choices of Thermo-plastic coated steel components. For optional colors choices see Specification Bulletin #SPC-CO-001.
- **Optional:** Color choices of powder coated steel frame components. See Specification Bulletin #SPC-CO-001.
- **Optional:** Frame is provided with a 3/8" x 15-3/4" x 15-3/4" steel base plate to bolt table to existing concrete pad. To specify add "/P" after the PQT in the model no., e.g. PQT/P/G-4VW. (Anchor bolts not included.)

RJ Thomas Mfg. Co., Inc.

PO Box 946 • Cherokee, IA 51012-0946 • PH: 712-225-5115 • 800-762-5002 • FAX: 712-225-5796
E-mail: pilotrock@rjthomas.com • Web Site: <https://www.pilotrock.com>

© 2023 RJ Thomas Mfg. Co., Inc. PILOT ROCK® Park Products is a registered trademark of RJ Thomas Mfg. Co., Inc.

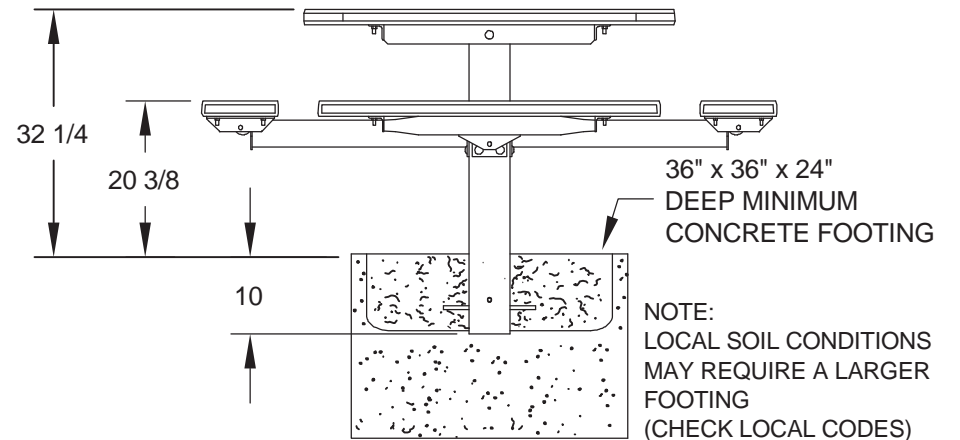
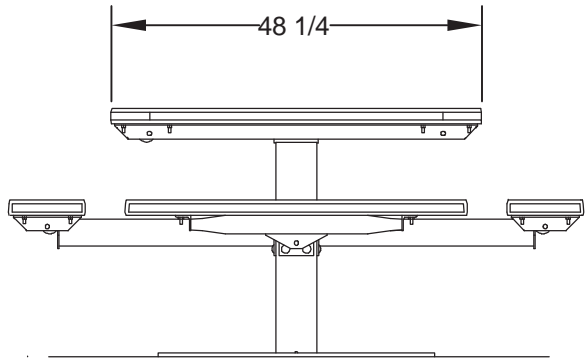
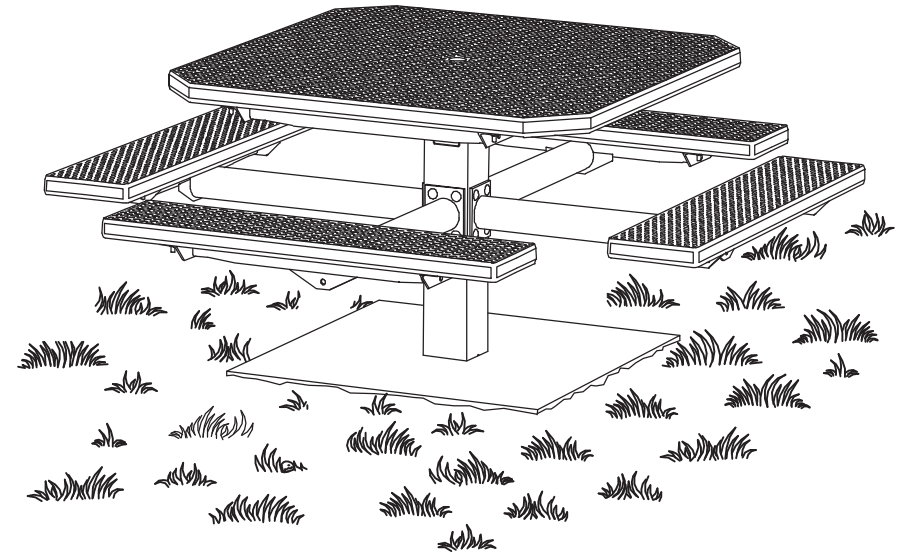
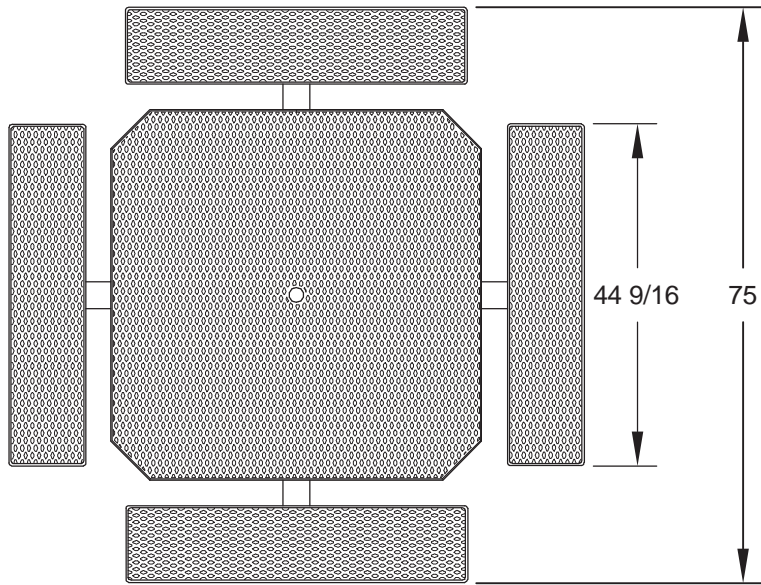

ALL DIMENSIONS IN INCHES

R. J. **THOMAS MFG. Co., INC.**
P.O. Box 946 • Cherokee, IA 51012

DRAWN BY
WWM

TITLE **PQT SERIES 4 FOOT EMBEDDED MOUNT SQUARE SINGLE PEDESTAL TABLE
WITH V-TYPE THERMO-PLASTIC COATED EXPANDED STEEL TOP AND SEATS**

DATE 3-12-10

DWG. NO. **AI-1700**