



Model SCXB/G-6VW10 Embedded Mount Bench
with hot-dip galvanized frames, 6 Ft. long with 10" wide brown
V-Type thermo-plastic coated expanded steel seat and back.

- **Extra heavy design to be stronger and more stable with a simple, clean style**
- **Sturdy, formed and welded steel frame construction**
- **Frames are Hot-Dip Galvanized after fabrication for superior corrosion resistance**
- **Thermo-plastic Coating heat fused to Expanded Steel Seat and Back for durability**
- **Thermo-plastic Coating formulated with U.V. stabilizers for ultraviolet protection**
- **Quality construction throughout**

AVAILABLE OPTIONS

- 4', 6' or 8' models
- Powder Coat Finish in choice of colors for steel frame components
- Choice of colors of Thermo-plastic Coating
- 10" or 12" seat and back width
- Armrests

SPECIFICATIONS:

- **Model SCXB** end frames are one-piece, welded construction with a back and seat bracket of 2-3/8" x 1-1/2" x 1/8" nominal sized, die-formed channel, and a 2.375" (2-3/8") O.D. post to meet 2" nominal steel pipe size specifications. Bench leg is designed to be permanently embedded in concrete footings.
- **Model SCXB/G-4** is 4 ft. long (nom.).
- **Model SCXB/G-6** is 6 ft. long (nom.).
- **Model SCXB/G-8** is 8 ft. long (nom.).
- **Standard:** Frames are hot-dip galvanized after fabrication to ASTM-A123 to maintain an average zinc coating of 2.0 oz. per sq. ft. of surface area (indicated by "/G" in model no., e.g. SCXB/G-4VW10).
- **Standard:** Seat and back are 10" wide.
- **V-Type** seat and back are each a one-piece welded construction, fabricated from a 3/4-#9 expanded steel surface with 10 ga. x 2-1/2" roll-formed vertical edges on all sides and reinforced by a 10 ga. die-formed angle substructure. Substructure includes all mounting holes for easy assembly of bench.
- **Standard:** All steel surfaces of the seat and back are covered with a thermo-plastic coating in a Brown color (indicated by "VW" in model no., e.g. SCXB/G-4VW10). The UV-stabilized thermo-plastic coating is applied in a multi step process of material preparation and finish application designed to permanently heat fuse and bond the finish to the steel. The thermo-plastic polyethylene finish is impact resistant, does not support mold or mildew, and the textured matte surface is less susceptible to marring and scuffing.
- All fasteners are provided for assembly.
- **Optional:** Color choices of powder coated steel frame components. For optional colors choices see Specification Bulletin #SPC-CO-001.
- **Optional:** Color choices of Thermo-plastic coated steel components. For optional colors choices see Specification Bulletin #SPC-CO-001.
- **Optional:** Seat and back can each be a 12" wide one-piece welded construction with 10 ga. x 2-1/2" roll-formed vertical edges on all sides. Indicate choice by changing "10" in model no. to "12", e.g. SCXB/G-4VW12.

RJ Thomas Mfg. Co., Inc.

PO Box 946 • Cherokee, IA 51012-0946 • PH: 712-225-5115 • 800-762-5002 • FAX: 712-225-5796
E-mail: pilotrock@rjthomas.com • Web Site: <http://www.pilotrock.com>

© 2008 RJ Thomas Mfg. Co., Inc. PILOT ROCK® Park Products is a registered trademark of RJ Thomas Mfg. Co., Inc.

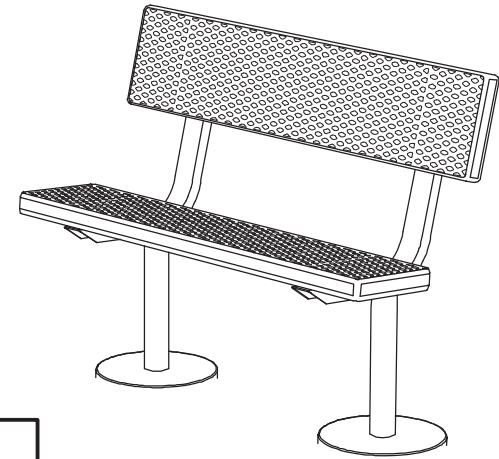
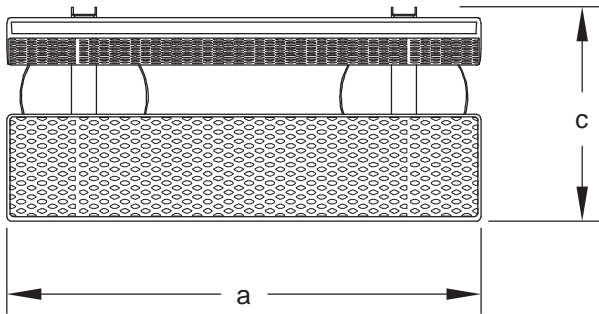

MODEL NUMBER	DIMENSION			
	a	b	c	d
SCXB-4-10	44	30	20-1/16	35
SCXB-6-10	72	51-3/4	20-1/16	35
SCXB-8-10	96	70	20-1/16	35
SCXB-4-12	48	36	21-1/16	36
SCXB-6-12	72	51-3/4	21-1/16	36
SCXB-8-12	96	70	21-1/16	36

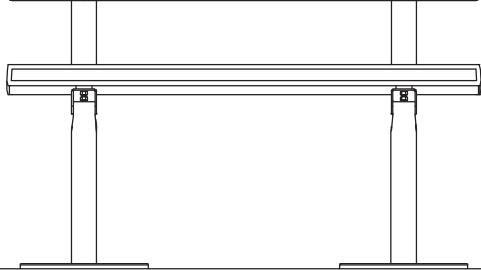
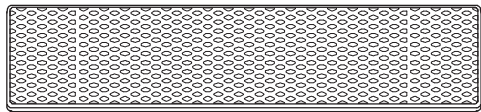

B
*CTR TO CTR
OF FRAME POSTS

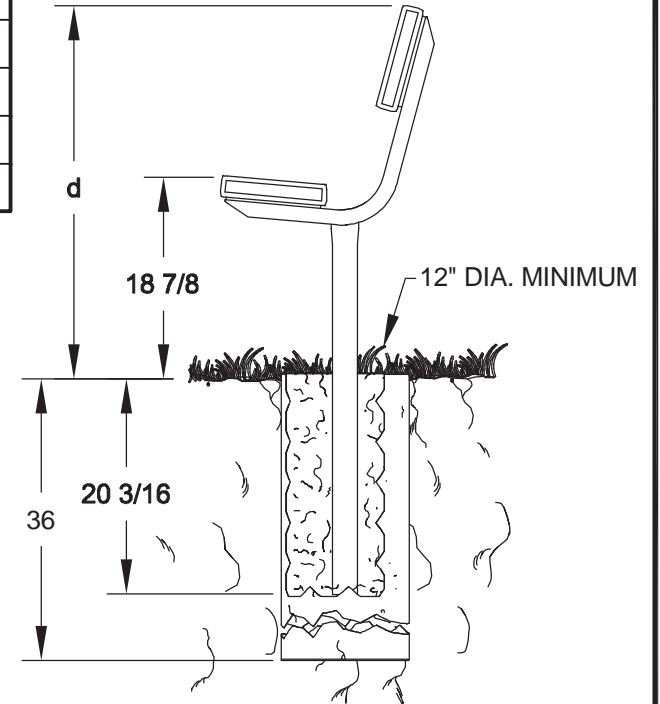

NOTE:
LOCAL SOIL
CONDITIONS
MAY REQUIRE
A LARGER
FOOTING
(CHECK LOCAL
CODES)

ALL DIMENSIONS IN INCHES

RJThomas Mfg. Co., Inc.
P.O. Box 946 • Cherokee, IA 51012-0946

DRAWN BY
WWM

TITLE MODEL SCXB EXTRA HEAVY DUTY 4, 6 AND 8 FOOT EMBEDDED MOUNT BENCH
WITH V-TYPE THERMO-PLASTIC COATED EXPANDED STEEL SEAT AND BACK

DATE 2-26-10

DWG. NO. AI-1639