



Model SQT3/CE-4HB/E Wheelchair accessible square portable table with burgandy powder coated frames and black thermo-plastic coated perforated steel top and seats. Top extended one foot on open side.

- **Three seats and one open side for wheelchair access**
- **Square design optimizes table top usage and creates a more intimate setting**
- **Nontip, nontrip walk-through design**
- **All welded corner frames are fabricated from 1-1/2" diameter steel pipe**
- **Cross braces strengthen the table**
- **Frames are hot dip galvanized after fabrication for superior corrosion resistance**
- **Thermo-plastic Coating heat fused to Perforated Steel Top Seats for durability**
- **Thermo-plastic Coating formulated with U.V. stabilizers for ultraviolet protection**
- **Quality construction throughout**

AVAILABLE OPTIONS

- **Powder Coat Finish in choice of colors for steel frame components**
- **Choice of colors of Thermo-plastic Coating**

SPECIFICATIONS:

- **Model SQT3-4** has a nominal 4' x 5' top. Overall dimensions are 73-3/8" x 75-1/8".
- Four corner frames are each a one-piece welded construction made from 1-1/2" dia. x 1/8" wall structural steel tubing and seat supports of 1-3/4" x 1-3/4" x 1/8" die formed steel angle. Two corner frames have opposing seat legs removed to provide a wheelchair accessible space under the extended side of the table top.
- Table frame design incorporates nontip, nontrip, walk-through features. Bends are tightly formed to prevent tipping when weight is on one side.
- Table top is extended 12" over open side of table creating ADA recommended space of 30" wide, 19" deep, and 27" from ground to bottom of table top for knee space, and minimum 9" above ground extending a total of 24" deep for toe space. Indicated by "/E" in model no., e.g. SQT3/G-4HW/E
- Nominal table height is 30". Nominal seat height is 17-1/2".
- Corner frames are connected by two cross braces constructed of 1-5/16" O.D. steel pipe.
- Top is supported and attached to corner frames by two 1-3/4" x 1-3/4" x 1/8" die formed steel angles.
- All fasteners are provided for assembly.
- **Standard:** All steel frame components are hot-dip galvanized after fabrication to ASTM-A123 to maintain an average zinc coating of 2.0 oz. per sq. ft. of surface area (indicated by "/G" in model no., e.g. SQT3/G-4HW/E).
- **H-Type** table top and seats are each a one-piece welded construction, fabricated from a 14 ga. perforated steel surface with 9/16" dia. holes in a 13/16" center to center in-line pattern and 2" roll-formed vertical edges on all sides (7 ga. on seats, 14 ga. on tops) and reinforced by strap and die-formed angle substructure. Substructure includes all mounting holes for assembly.
- **Standard:** All steel surfaces of the top and seats are covered with a thermo-plastic coating in a Brown color (indicated by "HW" in model no., e.g. SQT3/G-4HW/E). The UV-stabilized thermo-plastic coating is applied in a multi step process of material preparation and finish application designed to permanently heat fuse and bond the finish to the steel. The thermo-plastic polyethylene finish is impact resistant, does not support mold or mildew, and the textured matte surface is less susceptible to marring and scuffing.
- **Standard:** Table is provided with umbrella cup for mounting optional umbrella.
- **Optional:** All steel frame components shall have powder coat finish. See Specification Bulletin #SPC-CO-001.
- **Optional:** Color choices of Thermo-plastic coated steel components. For optional colors choices see Specification Bulletin #SPC-CO-001.

RJ Thomas Mfg. Co., Inc.

PO Box 946 • Cherokee, IA 51012-0946 • PH: 712-225-5115 • 800-762-5002 • FAX: 712-225-5796
E-mail: pilotrock@rjthomas.com • Web Site: <http://www.pilotrock.com>

© 2017 RJ Thomas Mfg. Co., Inc. PILOT ROCK® Park Products is a registered trademark of RJ Thomas Mfg. Co., Inc.

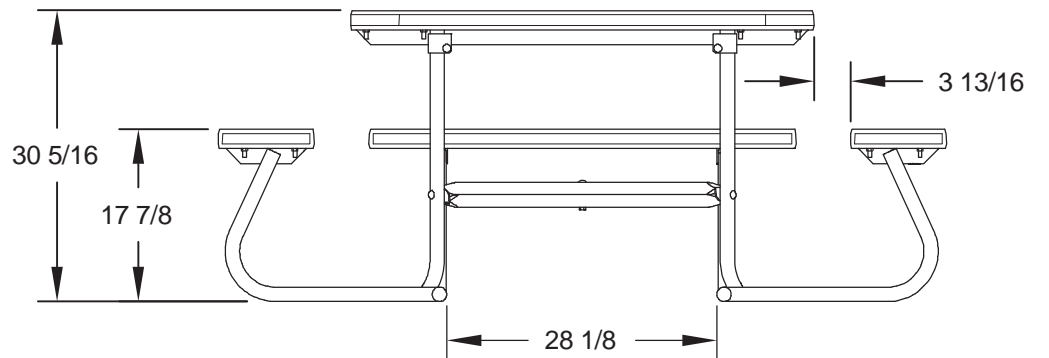
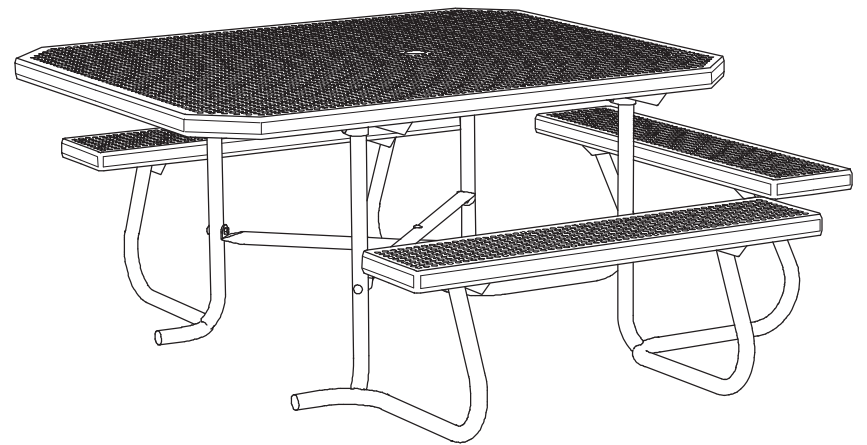
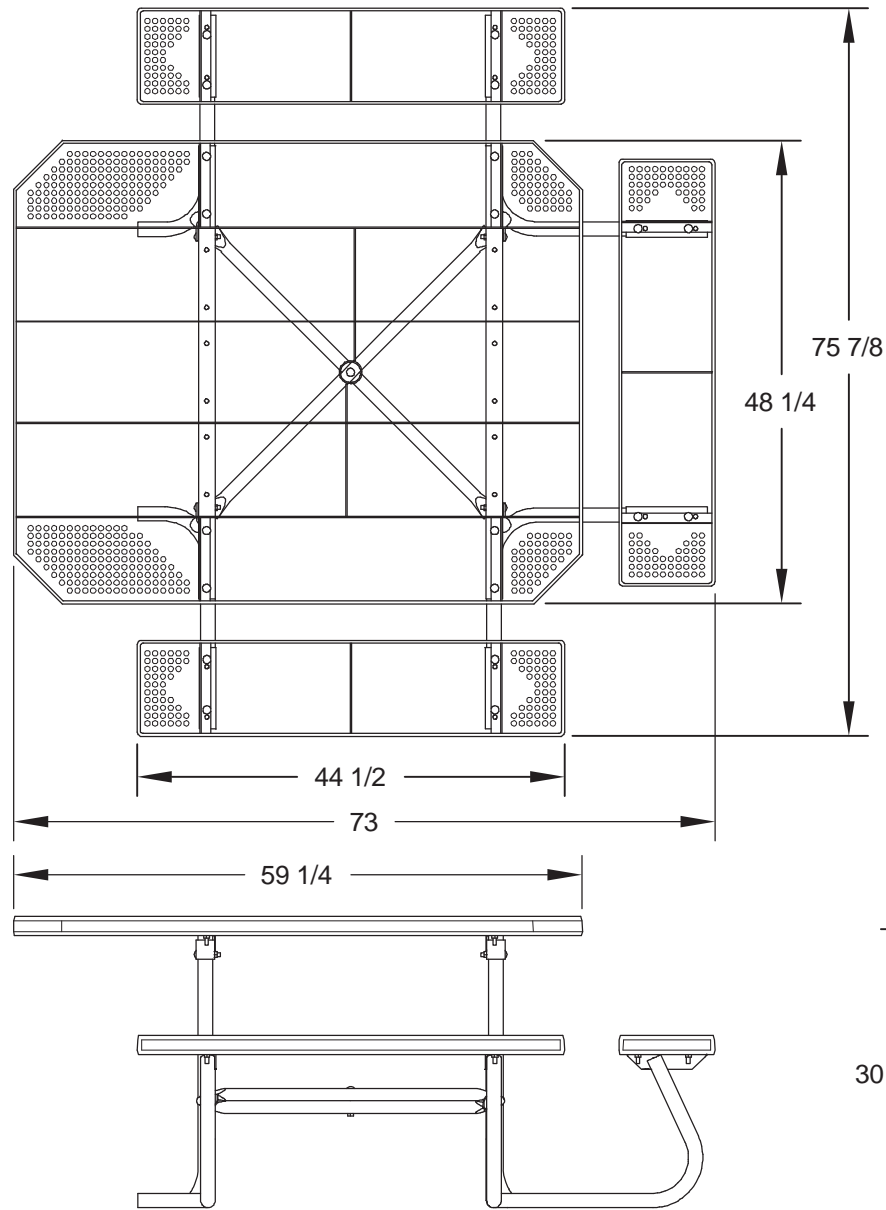

ALL DIMENSIONS IN INCHES

RJThomas Mfg. Co., Inc.
P.O. Box 946 • Cherokee, IA 51012-0946

DRAWN BY
WWM

TITLE **SQT3-4 SERIES 4 FOOT PORTABLE SQUARE TABLE
WITH H-TYPE THERMO-PLASTIC COATED PERFORATED
STEEL SEATS AND TOP- TOP EXTENDED ONE FOOT ON OPEN SIDE**

DATE **3-03-10**

DWG. NO. **AI-1834**