

SQT Series 3 and 4 Foot Portable Square Tables with Aluminum Top and Seats



*Model SQT/G-4AL 5 Plank, 48" Square Top, Portable Square Table
with Hot-Dip Galvanized Frame and Aluminum Planks*

- **Square design optimizes table top usage and creates a more intimate setting**
- **Square table fits into more compact areas**
- **Nontip, nontrip, walk-through design**
- **All welded corner frames are fabricated from 1-1/2" diameter steel pipe**
- **Frames are hot dip galvanized after fabrication for superior corrosion resistance**
- **Cross braces square up the corner frames and strengthen the table**
- **Seats and Top are Aluminum with a clear anodized maintenance-free finish**
- **Quality construction throughout**

AVAILABLE OPTIONS

3' or 4' square models

Powder Coat Finish in choice of colors for steel frame components

Powder Coat Finish in choice of colors for aluminum top and seats

Backrest attachments

Umbrellas

SPECIFICATIONS:

- **Model SQT-3** has a nominal 38" square table top utilizing (4) top planks.
- **Model SQT-4** has a nominal 48" square table top utilizing (5) top planks.
- Table frame design incorporates nontip, nontrip, walk-through features. Bends are tightly formed to prevent tipping when weight is on one side.
- Four SQT Series corner frames are each a one-piece welded construction made from 1-1/2" dia. x 1/8" wall structural steel tubing and seats supports of 1-3/4" x 1-3/4" x 1/8" die formed steel angle.
- Nominal table height is 30". Nominal seat height is 18".
- Top planks are supported and attached to corner frames by two 1-3/4" x 1-3/4" x 1/8" die formed steel angles.
- Corner frames are connected by two cross braces constructed of 1-5/16" O.D. steel pipe.
- All galvanized fasteners shall be provided for assembly.
- Aluminum is extruded 6063-T6 aluminum alloy in planks with dimensions equivalent to that of 2" x 10" nominal sized lumber. The plank design is 1-3/4" x 9-5/8" with four structural reinforcement ribs for greater rigidity. Aluminum planks are provided with a clear anodized finish as per anodizing specification 204 R1. Aluminum clips to fasten planks to frames are included.
- Channel end caps are of extruded 6063-T6 aluminum alloy provided with a clear anodized finish as per anodizing specification 204 R1. End caps are press fitted over ends of aluminum planks and mechanically fastened in place at the factory.
- Table top is assembled into single a unit at the factory with one-piece end caps across each end.
- **Standard:** All steel frame components are hot-dip galvanized after fabrication to ASTM-A123 to maintain an average zinc coating of 2.0 oz. per sq. ft. of surface area (indicated by "/G" in model no., e.g. SQT/G-3AL).
- **Optional:** All steel frame components have powder coat finish. For color choices see Specification Bulletin #SPC-CO-001.
- **Optional:** All top and seat planks and end caps have powder coat finish. For color choices see Specification Bulletin #SPC-CO-001.
- **Optional:** Table is provided with backrests. To specify, add "/B" to end of model no., e.g. SQT/G-4AL/B.
- **Optional:** Table is provided with umbrella holes in table tops and cup and collar sets for mounting umbrellas. To specify, add "/U" to the end of the model no., e.g. SQT/G-3AL/U.

RJ Thomas Mfg. Co., Inc.

PO Box 946 • Cherokee, IA 51012-0946 • PH: 712-225-5115 • 800-762-5002 • FAX: 712-225-5796

E-mail: pilotrock@rjthomas.com • Web Site: <http://www.pilotrock.com>

© 2017 RJ Thomas Mfg. Co., Inc. PILOT ROCK® Park Products is a registered trademark of RJ Thomas Mfg. Co., Inc.

**NOTE: SQT-3 TABLES HAVE (4) TOP PLANKS
SQT-4 TABLES HAVE (5) TOP PLANKS**

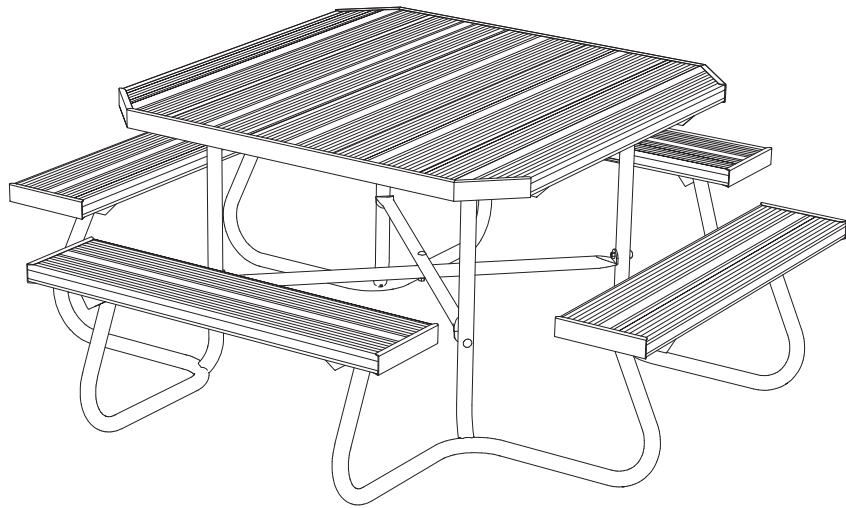

MODEL NUMBER	DIMENSION				
	a	b	c	d	e
SQT-3	65 5/16	38 5/8	33 15/16	3 3/4	37 15/16
SQT-4	75 5/16	48 1/4	40 15/16	4	47 15/16

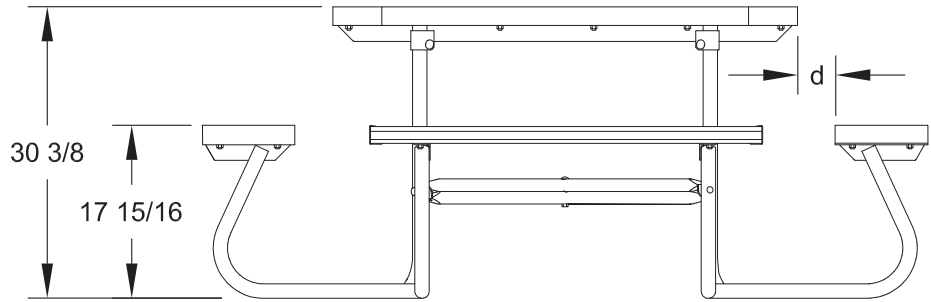
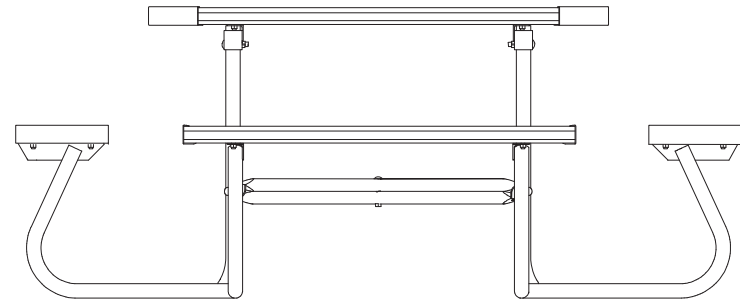
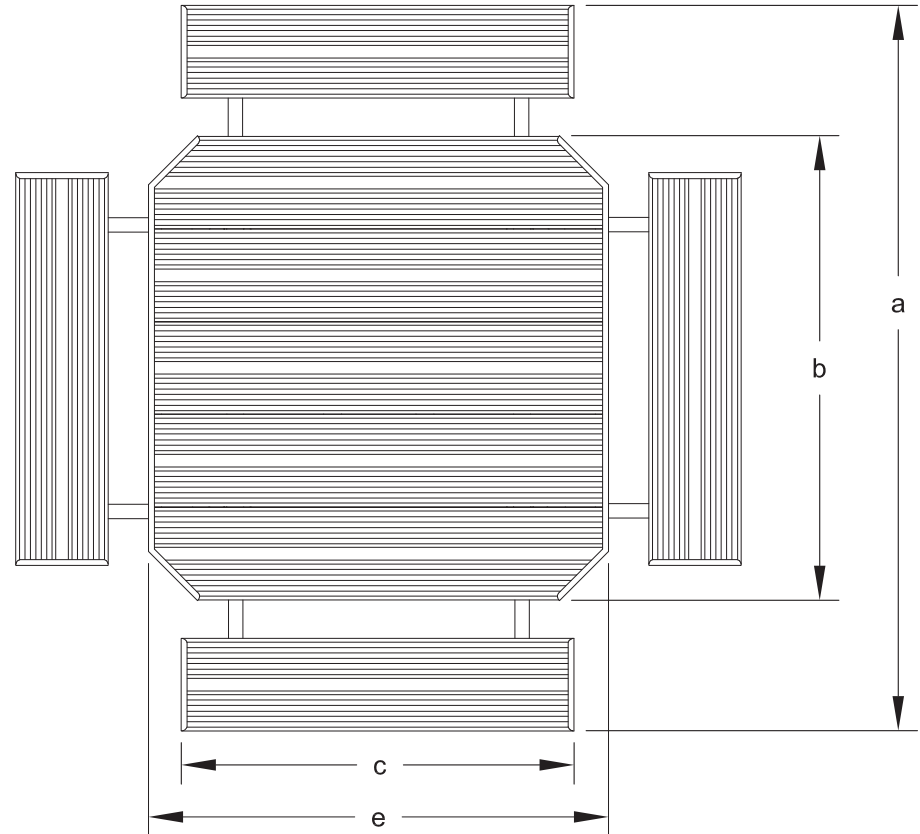

ALL DIMENSIONS IN INCHES

RJThomas Mfg. Co., Inc.
P.O. Box 946 • Cherokee, IA 51012-0946

DRAWN BY
WWM

TITLE SQT SERIES 3 AND 4 FOOT PORTABLE SQUARE TABLES WITH ALUMINUM TOP AND SEAT PLANKS

DATE 11-29-05

DWG. NO. **AI-1498**