

SQTK Series Portable Square Table for Kids with Aluminum Top and Seats



*Model SQTK/CU-4AE 48" square top,
portable square table with blue powder coated frames
and burgandy powder coated aluminum top and seats*

- **Scaled to fit children and their activities**
- **Square design optimizes table top usage and creates a more intimate setting**
- **Square table fits into more compact areas**
- **Nontip, nontrip, walk-through design**
- **All welded corner frames are fabricated from 1-1/2" diameter steel pipe**
- **Frames are hot dip galvanized after fabrication for superior corrosion resistance**
- **Cross braces square up the corner frames and strengthen the table**
- **Seats and Top are Aluminum with a clear anodized maintenance-free finish**
- **Quality construction throughout**

AVAILABLE OPTIONS

- Powder Coat Finish in choice of colors for steel frame components
- Powder coat finish in choice of colors for aluminum top and seats
- Umbrellas

SPECIFICATIONS:

- **Model SQTK-4** has a nominal 48" square table top. The table is scaled to fit children.
- Table frame design incorporates nontip, nontrip, walk-through features. Bends are tightly formed to prevent tipping when weight is on one side.
- Four SQTK Series corner frames are each a one-piece welded construction made from 1-1/2" dia. x 1/8" wall structural steel tubing and seat supports of 1-3/4" x 1-3/4" x 1/8" die formed steel angle.
- Nominal table height is 22". Nominal seat height is 12".
- Top planks are supported and attached to corner frames by two 1-3/4" x 1-3/4" x 1/8" die formed steel angles.
- Corner frames are connected by two cross braces constructed of 1-5/16" O.D. steel pipe.
- All galvanized fasteners shall be provided for assembly.
- Aluminum is extruded 6063-T6 aluminum alloy in planks with dimensions equivalent to that of 2" x 10" nominal sized lumber. The plank design is 1-3/4" x 9-5/8" with four structural reinforcement ribs for greater rigidity. Aluminum planks are provided with a clear anodized finish as per anodizing specification 204 R1. Aluminum clips to fasten planks to frames are included.
- Channel end caps are of extruded 6063-T6 aluminum alloy provided with a clear anodized finish as per anodizing specification 204 R1. End caps are press fitted over ends of aluminum planks and mechanically fastened in place at the factory.
- Table top is assembled into single a unit at the factory with one-piece end caps across each end.
- **Standard:** All steel frame components are hot-dip galvanized after fabrication to ASTM-A123 to maintain an average zinc coating of 2.0 oz. per sq. ft. of surface area (indicated by "/G" in model no., e.g. SQTK/G-4AL).
- **Optional:** All steel frame components have powder coat finish. For color choices see Specification Bulletin #SPC-CO-001.
- **Optional:** All top and seat planks and end caps have powder coat finish. For color choices see Specification Bulletin #SPC-CO-001.
- **Optional:** Table is provided with umbrella holes in table tops and cup and collar sets for mounting umbrellas. To specify, add "/U" to the end of the model no., e.g. SQTK/G-4AL/U.

RJThomas Mfg. Co., Inc.

PO Box 946 • Cherokee, IA 51012-0946 • PH: 712-225-5115 • 800-762-5002 • FAX: 712-225-5796

E-Mail: pilotrock@rjthomas.com • Web Site: <http://www.pilotrock.com>

© 2017 RJThomas Mfg. Co., Inc. PILOT ROCK® Park Products is a registered trademark of RJThomas Mfg. Co., Inc.

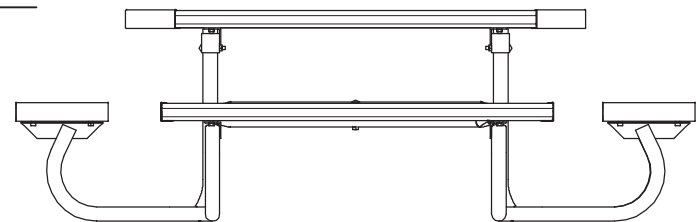
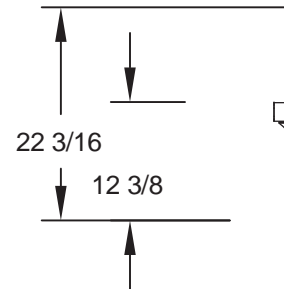
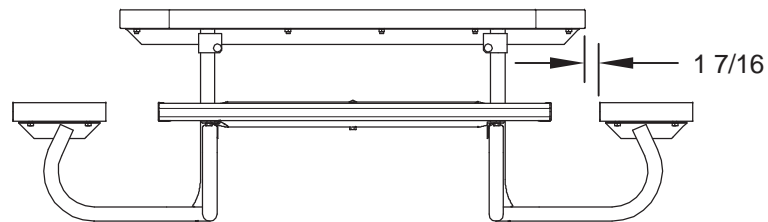
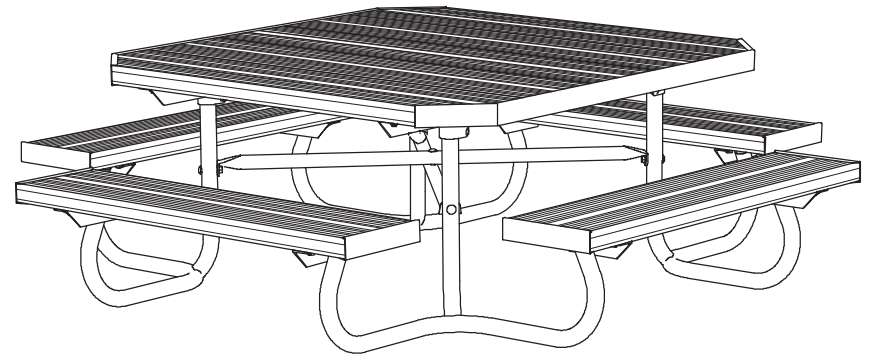
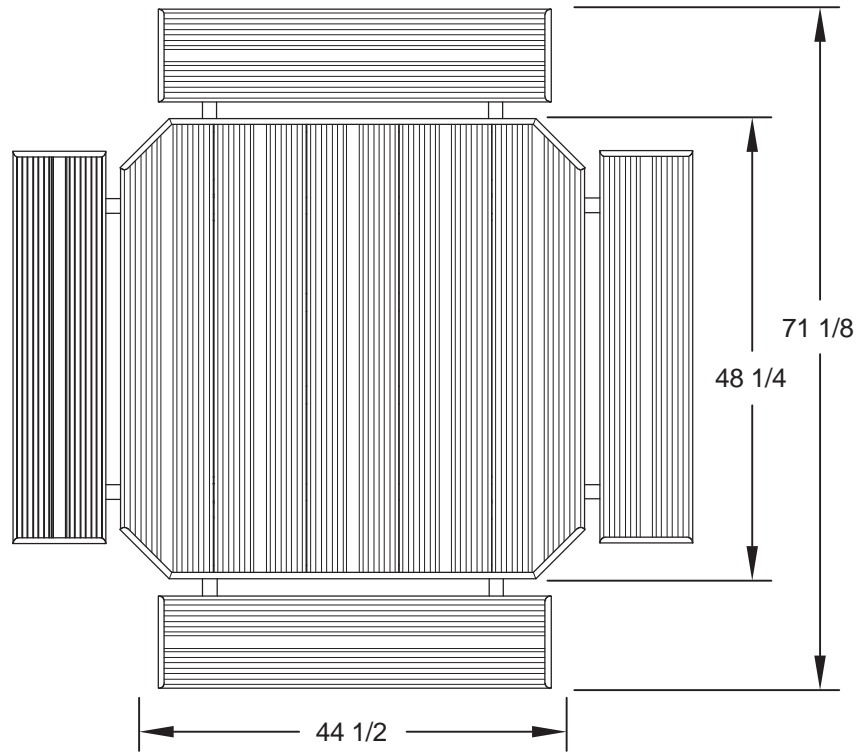

ALL DIMENSIONS IN INCHES

RJThomas Mfg. Co., Inc.
P.O. Box 946 • Cherokee, IA 51012-0946

DRAWN BY
WWM

TITLE **SQTK SERIES 4 FOOT PORTABLE SQUARE TABLE FOR KIDS WITH ALUMINUM TOP AND SEATS**

DATE **02-24-11**

DWG. NO. **AI-1991**