



*Model SQTK/CW-4HA 48" square top, portable square table with brown powder coat frames and gray H-Type thermo-plastic coated perforated steel seats and top*

- **Scaled to fit children and their activities**
- **Square design optimizes table top usage and creates a more intimate setting**
- **Square table fits into more compact areas**
- **Nontip, nontrip, walk-through design**
- **All welded corner frames are fabricated from 1-1/2" diameter steel pipe**
- **Cross braces square up the corner frames and strengthen the table**
- **Frames are hot dip galvanized after fabrication for superior corrosion resistance**
- **Thermo-plastic Coating heat fused to Perforated Steel Top and Seats for durability**
- **Thermo-plastic Coating formulated with U.V. stabilizers for ultraviolet protection**
- **Quality construction throughout**

#### **AVAILABLE OPTIONS**

- Powder Coat Finish in choice of colors for steel frame components
- Choice of colors of Thermo-plastic Coating
- Umbrella

#### **SPECIFICATIONS:**

- **Model SQTK-4** has a nominal 48" square table top. The table is scaled to fit children.
- Table frame design incorporates nontip, nontrip, walk-through features. Bends are tightly formed to prevent tipping when weight is on one side.
- Four SQTK Series corner frames are each a one-piece welded construction made from 1-1/2" dia. x 1/8" wall structural steel tubing and seat supports of 1-3/4" x 1-3/4" x 1/8" die formed steel angle.
- Nominal table height are 22". Nominal seat height is 12".
- Top is supported and attached to corner frames by two 1-3/4" x 1-3/4" x 1/8" die formed steel angles.
- Corner frames are connected by two cross braces constructed of 1-5/16" O.D. steel pipe.
- All fasteners are provided for table assembly.
- Table top and seats are each one-piece welded construction, fabricated from 14 ga. perforated steel with 2" die-formed edges and reinforced by 14 ga. x 1/2" steel bars and 14 ga. x 1-3/8" x 1/2" angle.
- **Standard:** All steel frame components are hot-dip galvanized after fabrication to ASTM-A123 to maintain an average zinc coating of 2.0 oz. per sq. ft. of surface area (indicated by "/G" following the SQTK in model no., e.g. SQTK/G-4HW).
- **Standard:** All steel surfaces of the top and seats are covered with a thermo-plastic coating in a Brown color (indicated by "HW" in model no., e.g. SQTK/G-4HW). The UV-stabilized thermo-plastic coating is applied in a multi step process of material preparation and finish application designed to permanently heat fuse and bond the finish to the steel. The thermo-plastic polyethylene finish is impact resistant, does not support mold or mildew, and the textured matte surface is less susceptible to marring and scuffing.
- **Standard:** Table is provided with umbrella cup for mounting optional umbrella.
- **Optional:** Color choices of powder coated steel frame components. See Specification Bulletin #SPC-CO-001.
- **Optional:** Color choices of Thermo-plastic coated steel components. For optional colors choices see Specification Bulletin #SPC-CO-001.

### **RJThomas Mfg. Co., Inc.**

PO Box 946 • Cherokee, IA 51012-0946 • PH: 712-225-5115 • 800-762-5002 • FAX: 712-225-5796

E-Mail: [pilotrock@rjthomas.com](mailto:pilotrock@rjthomas.com) • Web Site: <http://www.pilotrock.com>

© 2017 RJThomas Mfg. Co., Inc. PILOT ROCK® Park Products is a registered trademark of RJThomas Mfg. Co., Inc.

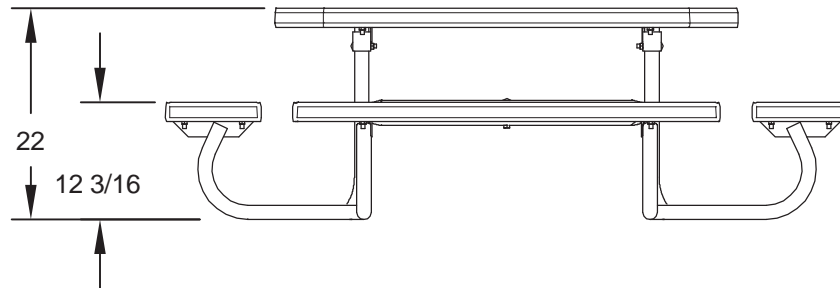
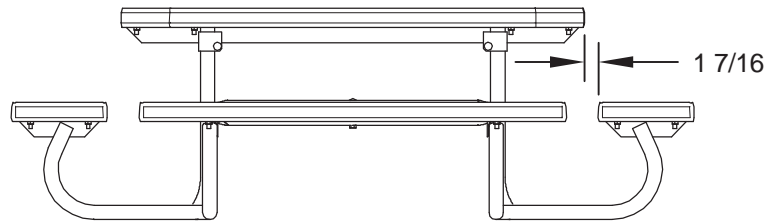
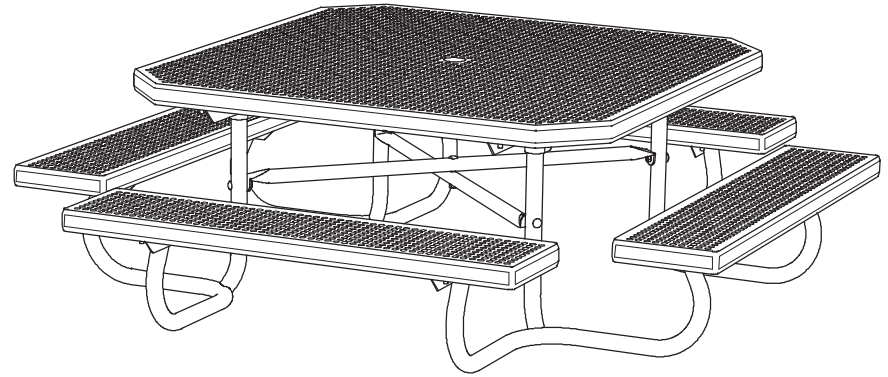
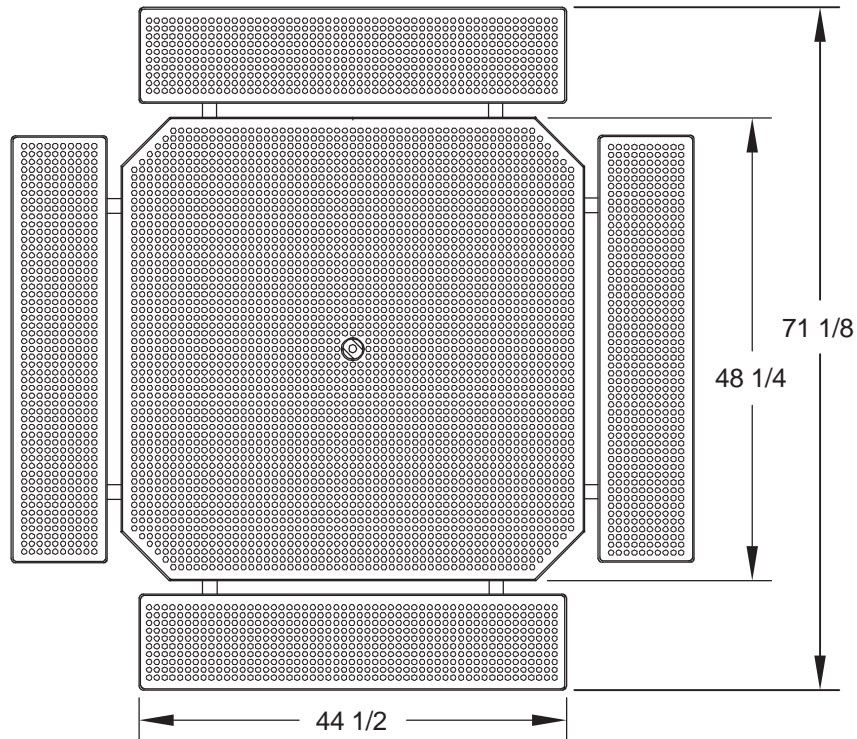

ALL DIMENSIONS IN INCHES

**RJThomas Mfg. Co., Inc.**  
P.O. Box 946 • Cherokee, IA 51012-0946

DRAWN BY  
**WWM**

TITLE **SQTK SERIES 4 FOOT PORTABLE SQUARE TABLE FOR KIDS WITH THERMO-PLASTIC COATED H-TYPE PERFORATED STEEL TOP AND SEATS**

DATE 02-22-11

DWG. NO. **AI-1989**