

Model SWRB 4, 6, and 8 Foot Embedded Mount Contour Bench with Lumber Timbers



*Model SWRB/G-6IB34 6 Ft. Embedded Mount
Bench with Hot Dip Galvanized Frames and
Indonesian Balau Wood 3" x 4" timbers.
Shown with optional armrests.*

- **Sturdy, formed and welded steel construction**
- **Contour design with Bull-nosed top and front timbers**
- **Indonesian Balau Wood Lumber**
- **Precision drilled 3" x 4" Timbers**
- **Quality construction throughout**

SPECIFICATIONS:

- **Model SWRB Series** end frames are one-piece welded construction with 2-1/2" x 2-1/2" square steel post. Seat brackets are constructed of 3/8" x 4" A-36 flat steel bar, die-formed for shape and reinforcement, to mount eight 3" x 4" timbers.
- Bench is designed to be permanently anchored by embedding bench legs in concrete footings.
- **Model SWRB-4** is a nom. 4 ft. in length.
- **Model SWRB-6** is a nom. 6 ft. in length.
- **Model SWRB-8** is a nom. 8 ft. in length.
- **Standard:** All steel frame components are hot-dip galvanized after fabrication to ASTM-A123 to maintain an average zinc coating of 2.0 oz. per sq. ft. of surface area (indicated by "/G" in model no., e.g. SWRB/G-4IB34).
- **Standard:** Lumber is Indonesian Balau Wood 3" x 4" nominal sized timbers (indicated by "IB34" in model no., e.g. SWRB/G-4IB34). All lumber is surface planed on all four sides; precision drilled for assembly; and has all exposed edges removed to a 3/8" radius. Top and front timbers have a bull-nose radius on outside edges.
- All fasteners are provided for assembly.
- **Optional:** Color choices of powder coated steel frame components. For optional colors choices see Specification Bulletin #SPC-CO-001.
- **Optional:** In lieu of carriage bolts, zinc plated lag screws shall be provided for timber connections – please specify when ordering.
- **Optional:** Construction Heart Redwood 3" x 4" timbers when available. Please inquire. (To specify, change "IB" in model no. to "CO" for Construction Heart Redwood, e.g. SWRB/G-4CO34.)

AVAILABLE OPTIONS

- 4', 6', or 8' models
- Powder Coat Finish in choice of colors for steel frame components
- Armrests

RJ Thomas Mfg. Co., Inc.

PO Box 946 • Cherokee, IA 51012-0946 • PH: 712-225-5115 • 800-762-5002 • FAX: 712-225-5796
E-mail: pilotrock@rjthomas.com • Web Site: <http://www.pilotrock.com>

© 2018 RJ Thomas Mfg. Co., Inc. PILOT ROCK® Park Products is a registered trademark of RJ Thomas Mfg. Co., Inc.

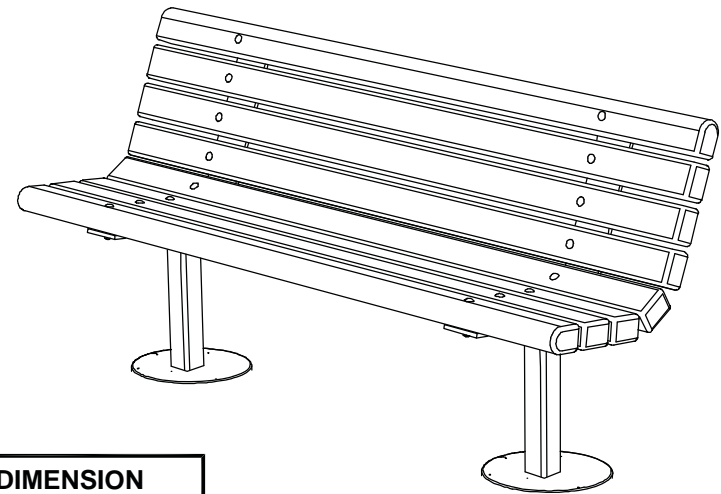
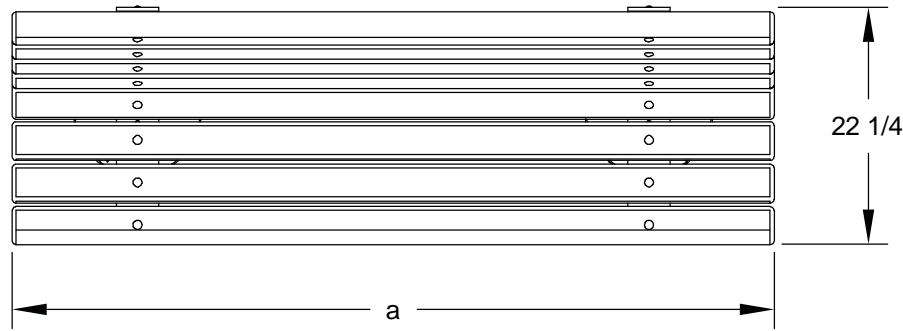

MODEL NUMBER	DIMENSION	
	a	b
SWRB-4	47-1/2	36
SWRB-6	71-1/2	48
SWRB-8	95-1/2	68

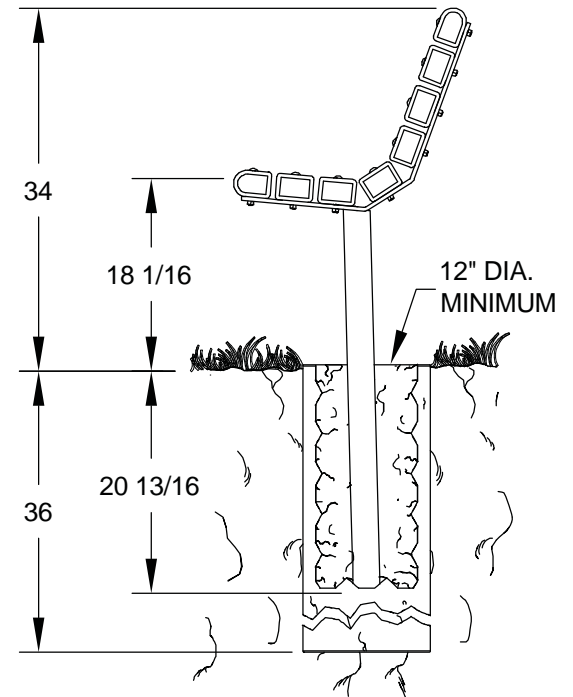
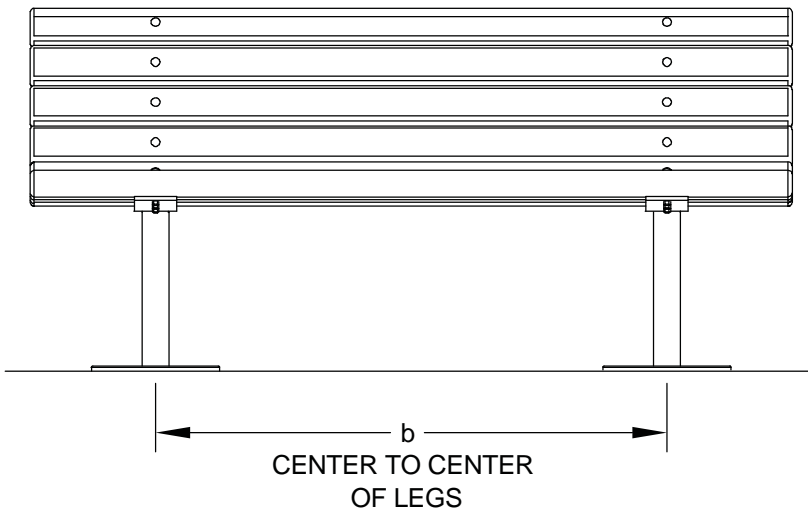

NOTE:
LOCAL SOIL
CONDITIONS
MAY REQUIRE
A LARGER
FOOTING
(CHECK LOCAL
CODES)

ALL DIMENSIONS IN INCHES

RJThomas Mfg. Co., Inc.
P.O. Box 946 • Cherokee, IA 51012-0946

DRAWN BY
WWM

TITLE MODEL SWRB 4, 6, AND 8 FOOT EMBEDDED MOUNT CONTOUR BENCH WITH 3" X 4"
LUMBER TIMBERS

DATE 9-04-08

DWG. NO. AI-1635