



Model T104K/G-4DU, 4 Ft. top, Round Portable Table for kids with hot dip galvanized frames and blue thermo-plastic coated D-Type expanded steel top and curved seats

- **Scaled to fit children and their activities**
- **Round design optimizes table top usage and creates a more intimate setting**
- **Nontip, nontrip, walk-through design**
- **All welded corner frames are fabricated from 1-1/2" diameter steel pipe**
- **Cross braces square up the corner frames and strengthen the table**
- **Frames are hot dip galvanized after fabrication for superior corrosion resistance**
- **Thermo-plastic Coating heat fused to Expanded Steel Top and Seats for durability**
- **Thermo-plastic Coating formulated with U.V. stabilizers for ultraviolet protection**
- **Quality construction throughout**

AVAILABLE OPTIONS

- **Powder Coat Finish in choice of colors for steel frame components**
- **Choice of colors of Thermo-plastic Coating**
- **Umbrella**

SPECIFICATIONS:

- Four **T100K Series** corner frames are each a one-piece welded construction made from 1-1/2" dia. x 1/8" wall structural steel tubing and seat supports of 1-3/4" x 1-3/4" x 1/8" die formed steel angle.
- Table frame design incorporates nontip, nontrip, walk-through features. Bends are tightly formed to prevent tipping when weight is on one side.
- **Model T104K/G-4** has a nom. 4 ft. diameter top. Curved seats are 40" long.
- Nominal table height is 20". Nominal seat height is 12".
- Top is supported and attached to corner frames by two 1-3/4" x 1-3/4" x 1/8" die formed steel angles.
- Corner frames are connected by two cross braces constructed of 1-5/16" O.D. 14 ga. wall steel pipe.
- All fasteners are provided for assembly.
- **Standard:** All steel frame components are hot-dip galvanized after fabrication to ASTM-A123 to maintain an average zinc coating of 2.0 oz. per sq. ft. of surface area (indicated by "/G" in model no., e.g. T104K/G-4DW).
- Table top and seats are each a one-piece welded construction, fabricated from a 3/4-#9 expanded steel surface with 10 ga. x 2" roll-formed vertical edges on all sides and reinforced by a 10 ga. die-formed angle substructure. Substructure includes all mounting holes for easy assembly of table.
- **Standard:** All steel surfaces of the top and seats are covered with a thermo-plastic coating in a Brown color (indicated by "DW" in model no., e.g. T104/G-4DW). The UV-stabilized thermo-plastic coating is applied in a multi step process of material preparation and finish application designed to permanently heat fuse and bond the finish to the steel. The thermo-plastic polyethylene finish is impact resistant, does not support mold or mildew, and the textured matte surface is less susceptible to marring and scuffing.
- **Optional:** Color choices of powder coated steel frame components. For optional colors choices see Specification Bulletin #SPC-CO-001.
- **Optional:** Color choices of Thermo-plastic coated steel components. For optional colors choices see Specification Bulletin #SPC-CO-001.
- **Standard:** Table is provided with umbrella cup for mounting optional umbrella.

RJThomas Mfg. Co., Inc.

PO Box 946 • Cherokee, IA 51012-0946 • PH: 712-225-5115 • 800-762-5002 • FAX: 712-225-5796

E-Mail: pilotrock@rjthomas.com • Web Site: <http://www.pilotrock.com>

© 2017 RJThomas Mfg. Co., Inc. PILOT ROCK® Park Products is a registered trademark of RJThomas Mfg. Co., Inc.

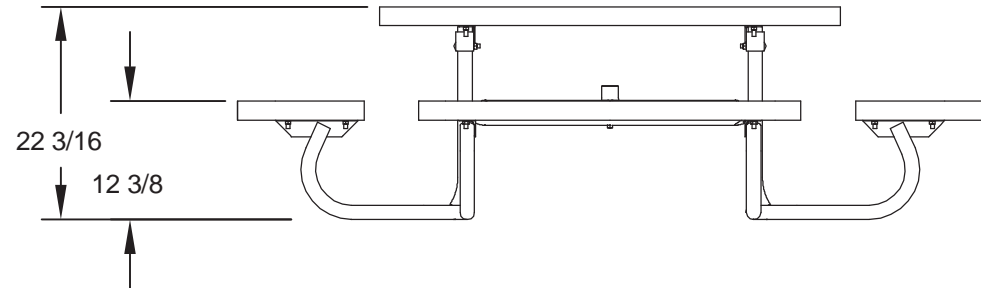
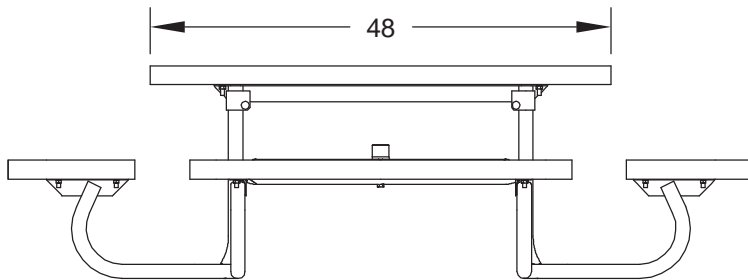
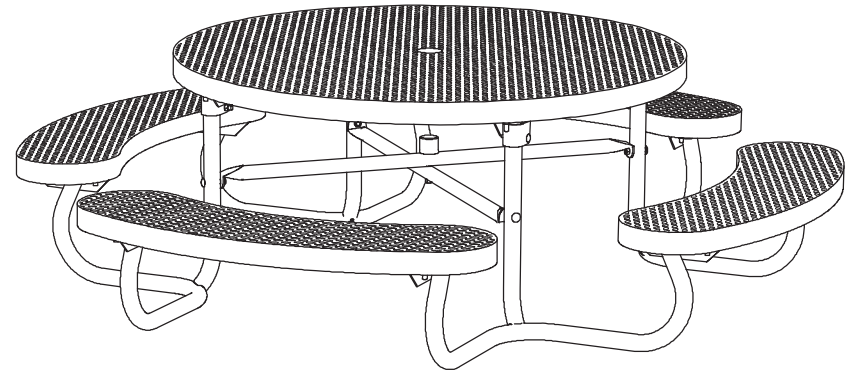
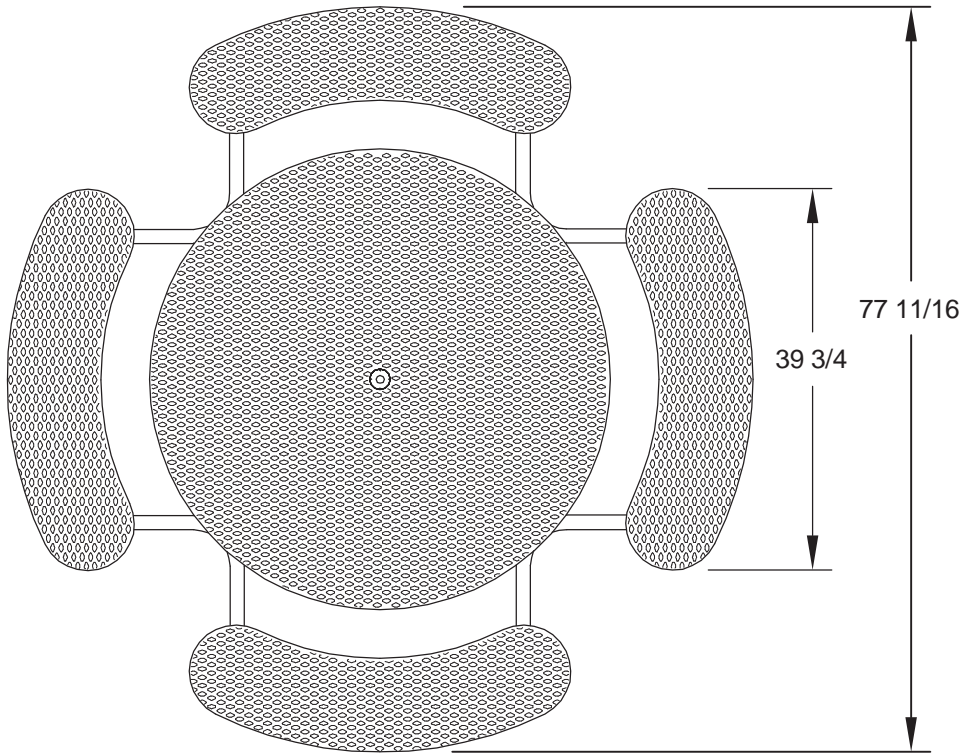

ALL DIMENSIONS IN INCHES

RJThomas Mfg. Co., Inc.
P.O. Box 946 • Cherokee, IA 51012-0946

DRAWN BY
WWM

TITLE T100K SERIES 4 FOOT PORTABLE ROUND TABLE FOR KIDS WITH THERMO-PLASTIC
COATED D-TYPE EXPANDED STEEL TOP AND CURVED SEATS

DATE 03-07-11

DWG. NO. AI-1998