



Model T214/CB-4RR Portable Round Table
with black powder coat frames, with red D-Type thermo-plastic coated
4 ft. dia. perforated steel top, center hub, and round seats.

- **Bolt together frame design is fabricated from 2-3/8" O.D. steel pipe**
- **Four round seats accommodate four adults**
- **Thermo-plastic coated center hub secures legs, includes hole for optional umbrella**
- **Frames are hot dip galvanized after fabrication for superior corrosion resistance**
- **Thermo-plastic Coating heat fused to Perforated Steel Top and Seats for durability**
- **Thermo-plastic Coating formulated with U.V. stabilizers for ultraviolet protection**
- **Quality construction throughout**

AVAILABLE OPTIONS

- Powder Coat Finish in choice of colors for steel frame components**
- Choice of colors of Thermo-plastic Coating**
- Umbrella**

SPECIFICATIONS:

- **T200 Series** frame legs are each a one-piece welded construction, fabricated from 2.375" (2-3/8") O.D. x 10 ga. wall steel pipe to meet 2" nominal steel pipe size specifications and 10 ga. (1/8") thick steel die-formed steel brackets for attaching the seats and tops.
- **Model T214/G-4** has a nom. 4 ft. diameter top. Round seats is 16" in diameter.
- Nominal table height is 30". Nominal seat height is 17-1/2".
- All fasteners are provided for assembly.
- **Standard:** All steel frames components are hot-dip galvanized after fabrication to ASTM-A123 to maintain an average zinc coating of 2.0 oz. per sq. ft. of surface area (indicated by "/G" in model no., e.g. T214/G-4RW).
- Table top and seats are each one-piece welded construction, fabricated from 14 ga. perforated steel surface with 10 ga. x 2" formed vertical edges on all sides and reinforced by a 10 ga. die-formed angle substructure. Substructure includes all mounting holes for easy assembly.
- Center hub is a one-piece welded construction, fabricated from 14 ga. perforated steel surface with 2" x 1/2" formed vertical edges on all sides and reinforced by four 10 ga. flat steel straps.
- **Standard:** All steel surfaces of the top, center hub, and seats are covered with a thermo-plastic coating in a Brown color (indicated by "RW" in model no., e.g. T214/G-4RW). The UV-stabilized thermo-plastic coating is applied in a multi step process of material preparation and finish application designed to permanently heat fuse and bond the finish to the steel. The thermo-plastic polyethylene finish is impact resistant, does not support mold or mildew, and the textured matte surface is less susceptible to marring and scuffing.
- Table top and center hub include a reinforced center hole for installation of optional umbrella with 1-1/2" dia. pole.
- **Optional:** Color choices of powder coated steel frame components. See Specification Bulletin #SPC-CO-001.
- **Optional:** Color choices of Thermo-plastic coated steel components. For optional colors choices see Specification Bulletin #SPC-CO-001.
- **Optional:** An umbrella is available. Please inquire for details.

RJ Thomas Mfg. Co., Inc.

PO Box 946 • Cherokee, IA 51012-0946 • PH: 712-225-5115 • 800-762-5002 • FAX: 712-225-5796
E-mail: pilotrock@rjthomas.com • Web Site: <http://www.pilotrock.com>

© 2018 RJ Thomas Mfg. Co., Inc. PILOT ROCK® Park Products is a registered trademark of RJ Thomas Mfg. Co., Inc.

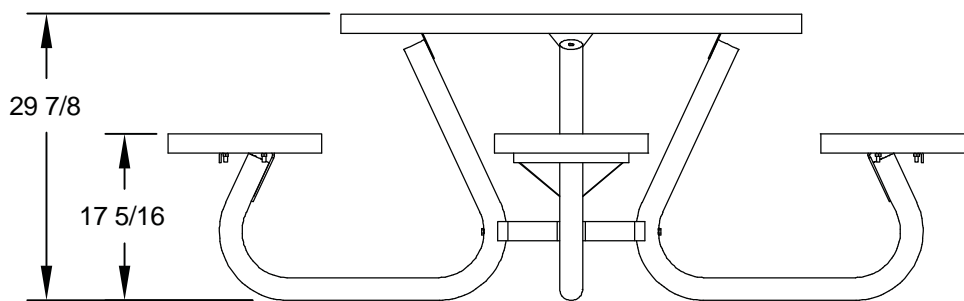
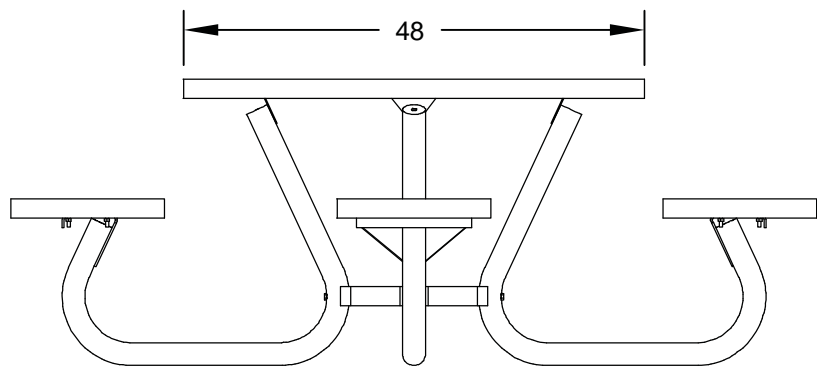
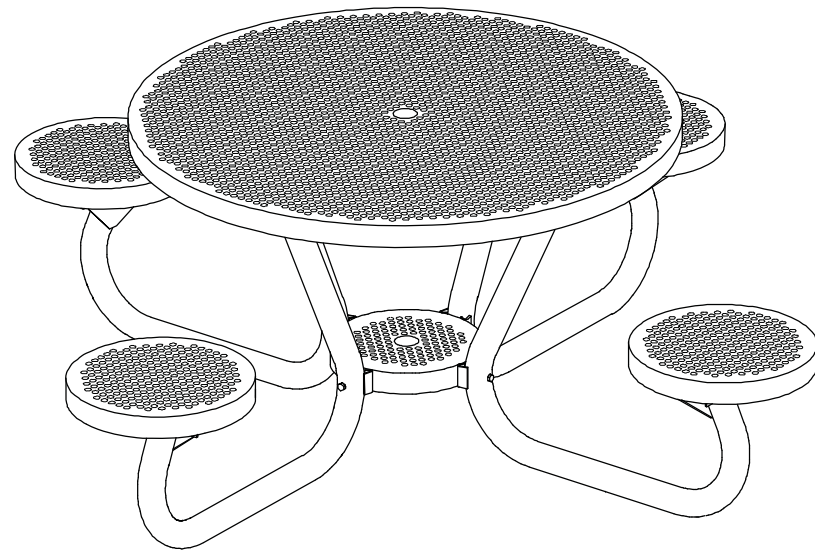
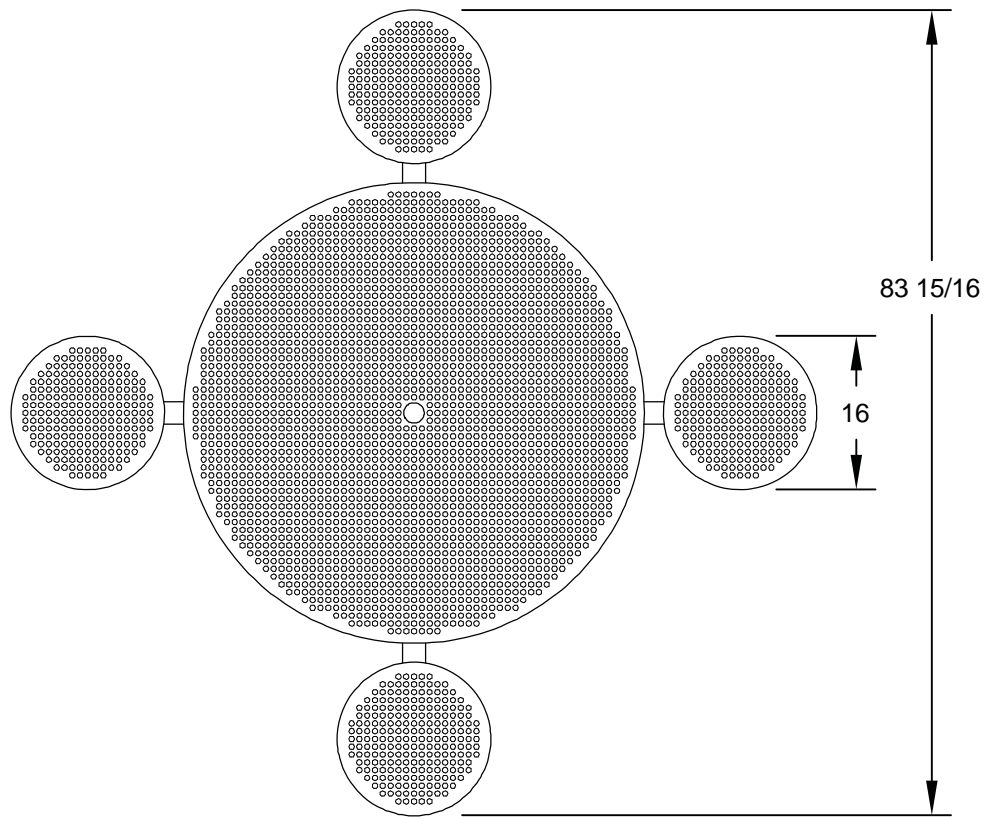

ALL DIMENSIONS IN INCHES

RJThomas Mfg. Co., Inc.
P.O. Box 946 • Cherokee, IA 51012-0946

DRAWN BY
WWM

TITLE **MODEL T214 PORTABLE BOLT TOGETHER ROUND TABLE
WITH R-TYPE THERMO-PLASTIC COATED
PERFORATED STEEL TOP AND ROUND SEATS**

DATE 3-04-10

DWG. NO. **AI-1665**