



Model T603/CU-8DA 8 ft. Wheelchair Accessible Caterpillar style rectangular table with blue powder coated frames and gray thermo-plastic coated expanded steel top and seats. Table provides access for a wheelchair at each end, one full length seat, and two short seats.

- **ADA compliant access for two wheelchairs**
- **Choice of seating configurations for full length or split seats**
- **All welded end frames are fabricated from 2-3/8" diameter steel pipe**
- **Diagonal braces align and strengthen entire table**
- **Frames are hot dip galvanized after fabrication for superior corrosion resistance**
- **Thermo-plastic Coating heat fused to Expanded Steel Top and Seats for durability**
- **Thermo-plastic Coating formulated with U.V. stabilizers for ultraviolet protection**

AVAILABLE OPTIONS

- **6, 8, or 10 ft. lengths**
- **Powder Coat Finish in choice of colors for steel frame components**
- **Choice of colors of Thermo-plastic Coating**

SPECIFICATIONS:

- **T600 Series** end frames are one-piece welded construction, fabricated from 2.375" O.D. (2-3/8" O.D.) steel pipe to meet 2" nominal steel pipe size specifications with 2" x 2" x 3/16" A-36 structural grade steel angle attaching the seats and top. Welded mounting plates with 9/16" dia. holes allow table to be permanently anchored to hard surfaces. Anchors not included.
- Table frame design incorporates step-over or walk-through design depending on seat configuration. Short seats are supported by a 7 ga. steel plate bracket. Gap between seats allows walk-through access.
- Table provides ADA compliant access for a wheelchair at each end of the table: 30" wide, 19" deep, and 27" from ground to bottom of table top for knee space, and minimum 9" above ground extending a total of 24" deep for toe space.
- Nominal table height is 30". Nominal seat height is 18".
- Frames are supported by diagonal braces of 1-5/16" O.D. x 14 ga. wall steel pipe connected to the table top designed to align and provide attachment to the table top.
- All fasteners are provided for assembly.
- **Standard:** All steel frame components are hot-dip galvanized after fabrication to ASTM-A123 to maintain an average zinc coating of 2.0 oz. per sq. ft. of surface area (indicated by "/G" in model no., e.g. T602/G-6DW).
- **D-Type** table top and seats are each a one-piece welded construction, fabricated from a 3/4-#9 expanded steel surface with 2" roll-formed 14 ga. steel vertical edges on all sides and reinforced by a strap and die-formed angle substructure. Substructure includes all mounting holes for easy assembly of table.
- **Standard:** All steel surfaces of the top and seats are covered with a thermo-plastic coating in a Brown color (indicated by "DW" in model no., e.g. T602/G-6DW). The UV-stabilized thermo-plastic coating is applied in a multi step process of material preparation and finish application designed to permanently heat fuse and bond the finish to the steel. The thermo-plastic polyethylene finish is impact resistant, does not support mold or mildew, and the textured matte surface is less susceptible to marring and scuffing.
- **Optional:** All steel frame components have powder coat finish. See Specification Bulletin #SPC-CO-001.
- **Optional:** Color choices of Thermo-plastic coated steel components. For optional colors choices see Specification Bulletin #SPC-CO-001.

Available Lengths and Seat Arrangements				
Model	Lgth./ft. (nom)	# of Frames	# of Full Seats	# of Short Seats
T602/G-6	6	2	(2) x 71-7/8"	None
T602/G-8	8	2	(2) x 95-7/8"	None
T602/G-10	10	3	(2) x 120"	None
T603/G-8	8	2	(1) x 95-7/8"	(2) x 33-3/4"
T604/G-8	8	2	None	(4) x 33-3/4"
T604/G-10	10	3	(1) x 120"	(3) x 33-3/4"
T606/G-10	10	3	None	(6) x 33-3/4"

RJ Thomas Mfg. Co., Inc.

PO Box 946 • Cherokee, IA 51012-0946 • PH: 712-225-5115 • 800-762-5002 • FAX: 712-225-5796
 E-mail: pilotrock@rjthomas.com • Web Site: http://www.pilotrock.com

© 2008 RJ Thomas Mfg. Co., Inc. PILOT ROCK® Park Products is a registered trademark of RJ Thomas Mfg. Co., Inc.

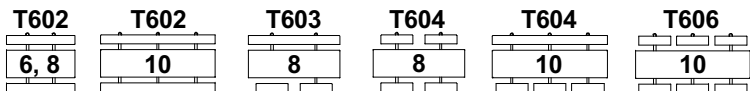
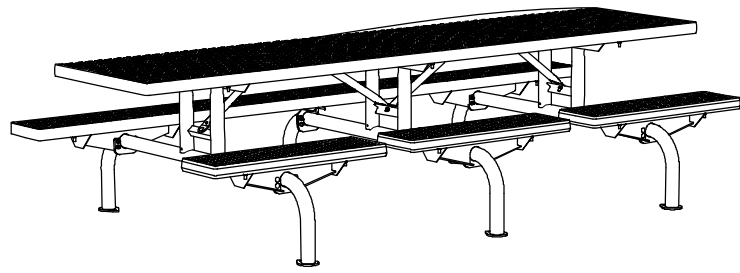
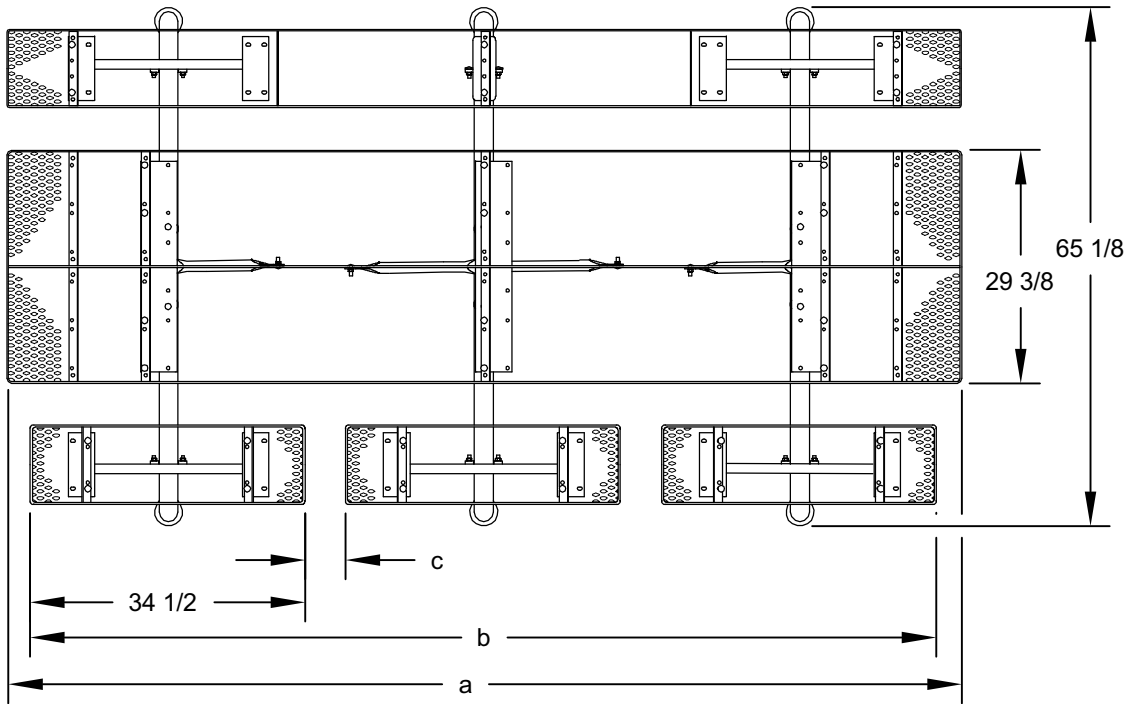

Model Number	DIMENSION				
	a	b	c	d	e
T602-6	71 7/8	71 7/8	NA	NA	27 1/2
T602-8	95 7/8	95 7/8	NA	NA	45 3/4
T602-10	120	120	NA	39 9/16	79 1/8
T603-8	95 7/8	80 1/4	11 1/4	NA	45 3/4
T604-8	95 7/8	80 1/4	11 1/4	NA	45 3/4
T604-10	120	113 7/8	5 3/16	39 5/8	79 1/4
T606-10	120	113 7/8	5 3/16	39 5/8	79 1/4

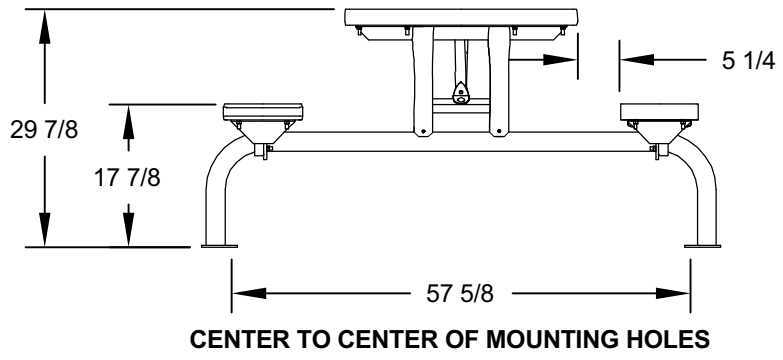
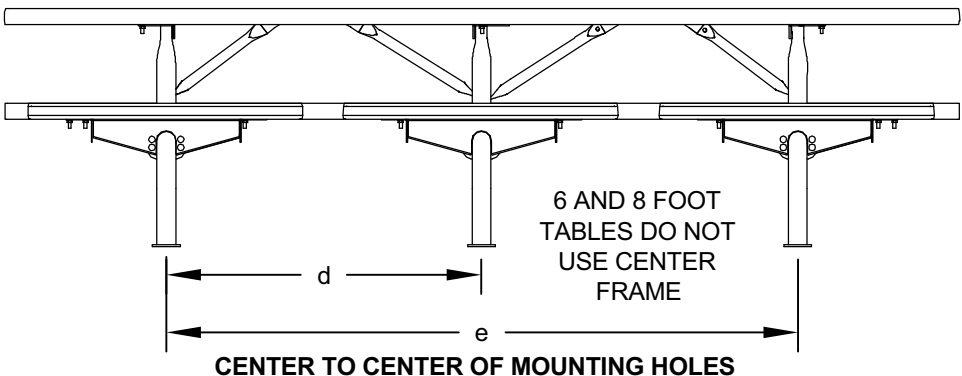

ALL DIMENSIONS IN INCHES

RJThomas Mfg. Co., Inc.
P.O. Box 946 • Cherokee, IA 51012-0946

DRAWN BY
WWM

TITLE T600 SERIES CATERPILLAR STYLE 6, 8, AND 10 FOOT RECTANGULAR TABLE WITH THERMO-PLASTIC COATED D-TYPE EXPANDED STEEL TOP AND SEATS

DATE 5-18-10

DWG. NO. **AI-1941**