

T600 Series Caterpillar Style 6, 8, and 10 Foot Rectangular Table with Lumber Top and Seats



Model T603/G-8UP 8 ft. Wheelchair Accessible Caterpillar style rectangular table with hot dip galvanized frames and untreated #1 Southern Yellow Pine lumber planks. Table provides access for a wheelchair at each end, one full length seat, and two short seats.

- **ADA compliant access for two wheelchairs**
- **Choice of seating configurations for full length or split seats**
- **All welded end frames are fabricated from 2-3/8" diameter steel pipe**
- **Die-formed center channel and diagonal braces align and strengthen entire table**
- **Frames are hot dip galvanized after fabrication for superior corrosion resistance**
- **Precision drilled, Untreated #1 Southern Yellow Pine Seat and Top Planks**

AVAILABLE OPTIONS

- 6, 8, or 10 ft. lengths
- Powder Coat Finish in choice of colors for steel frame components
- Pressure treated #1 Southern Yellow Pine lumber

SPECIFICATIONS:

- **T600 Series** end frames are one-piece welded construction, fabricated from 2.375" O.D. (2-3/8" O.D.) steel pipe to meet 2" nominal steel pipe size specifications with 2" x 2" x 3/16" A-36 structural grade steel angle attaching the seats and top. Welded mounting plates with 9/16" dia. holes allow table to be permanently anchored to hard surfaces. Anchors not included.
- Table frame design incorporates step-over or walk-through design depending on seat configuration. Short seats are supported by a 7 ga. steel plate bracket. Gap between seats allows walk-through access.
- Table provides ADA compliant access for a wheelchair at each end of the table: 30" wide, 19" deep, and 27" from ground to bottom of table top for knee space, and minimum 9" above ground extending a total of 24" deep for toe space.
- Nominal table height is 29-1/2". Nominal seat height is 17-1/2".
- Frames are supported by diagonal braces of 1-5/16" O.D. x 14 ga. wall steel pipe connected to a die-formed steel channel designed to align and provide attachment to the table top.
- All fasteners are provided for assembly.
- **Standard:** All steel frame components are hot-dip galvanized after fabrication to ASTM-A123 to maintain an average zinc coating of 2.0 oz. per sq. ft. of surface area (indicated by "/G" in model no., e.g. T602/G-6UP).
- **Standard:** Lumber is Untreated #1 grade Southern Yellow Pine (indicated by "UP" in model no., e.g. T602/G-6UP) 2" x 10" nominal sized planks, kiln dried to reduce moisture content. All lumber is precision drilled to facilitate assembly and has all exposed edges removed to a 3/8" radius.
- Two 1-5/8" x 1-5/16" x 14 ga. x 28" pregalvanized steel end caps are provided to align ends of top planks.
- **Optional:** Treated #1 Southern Yellow Pine is readily available and is pressure treated and kiln dried after treatment (KDAT) to preserve wood against decay. (To specify, change "UP" in model no. to "TP", e.g. T602/G-6TP.)
- **Optional:** All steel frame components have powder coat finish. See Specification Bulletin #SPC-CO-001.

Available Lengths and Seat Arrangements				
Model	Lgth./ft. (nom)	# of Frames	# of Full Seats	# of Short Seats
T602/G-6	6	2	(2) x 71-1/2"	None
T602/G-8	8	2	(2) x 95-1/2"	None
T602/G-10	10	3	(2) x 119-1/2"	None
T603/G-8	8	2	(1) x 95-1/2"	(2) x 33-3/8"
T604/G-8	8	2	None	(4) x 33-3/8"
T604/G-10	10	3	(1) x 119-1/2"	(3) x 33-3/8"
T606/G-10	10	3	None	(6) x 33-3/8"

RJ Thomas Mfg. Co., Inc.

PO Box 946 • Cherokee, IA 51012-0946 • PH: 712-225-5115 • 800-762-5002 • FAX: 712-225-5796
 E-mail: pilotrock@rjthomas.com • Web Site: <http://www.pilotrock.com>

© 2008 RJ Thomas Mfg. Co., Inc. PILOT ROCK® Park Products is a registered trademark of RJ Thomas Mfg. Co., Inc.

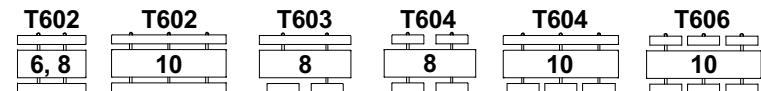
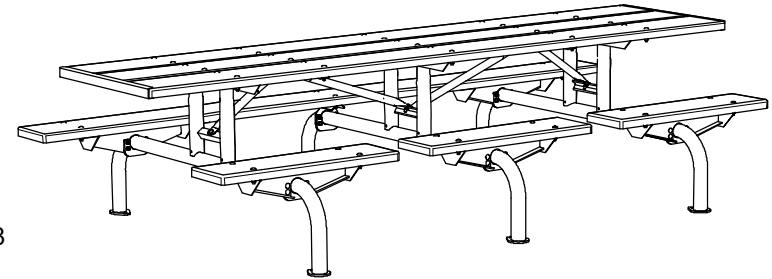
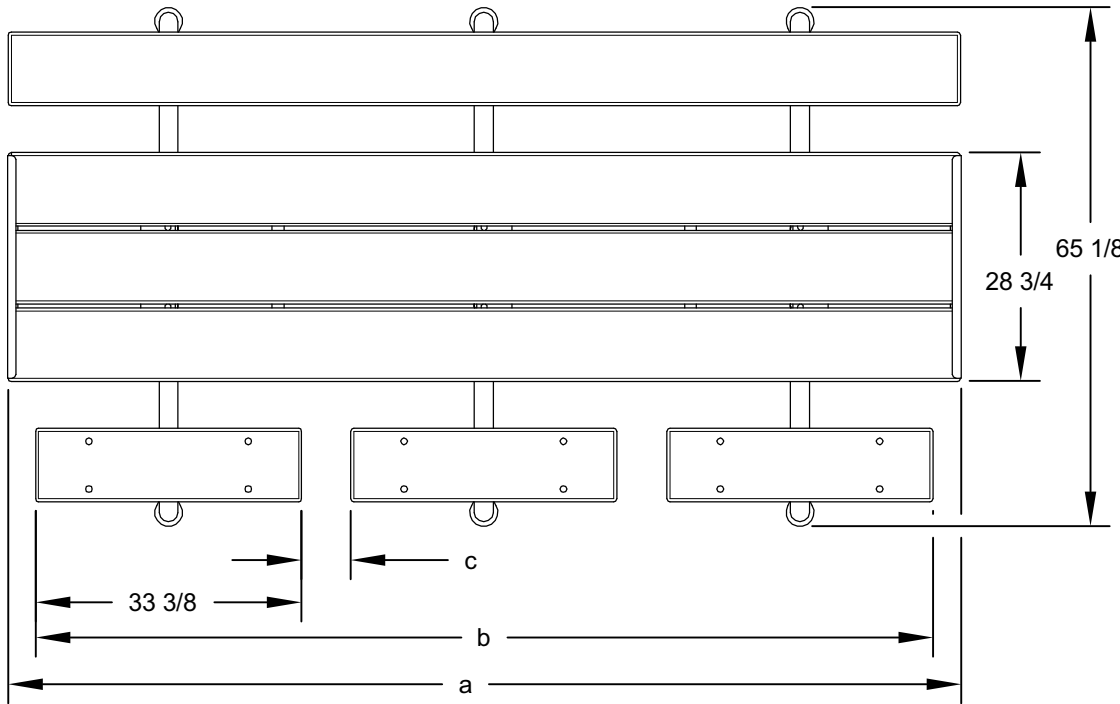

Model Number	DIMENSION				
	a	b	c	d	e
T602-6	71 5/8	71 1/2	NA	NA	27 1/2
T602-8	95 5/8	95 1/2	NA	NA	45 3/4
T602-10	119 5/8	119 1/2	NA	39 9/16	79 1/8
T603-8	95 5/8	79 1/8	12 3/8	NA	45 3/4
T604-8	95 5/8	79 1/8	12 3/8	NA	45 3/4
T604-10	119 5/8	112 5/8	6 1/4	39 9/16	79 1/8
T606-10	119 5/8	112 5/8	6 1/4	39 9/16	79 1/8

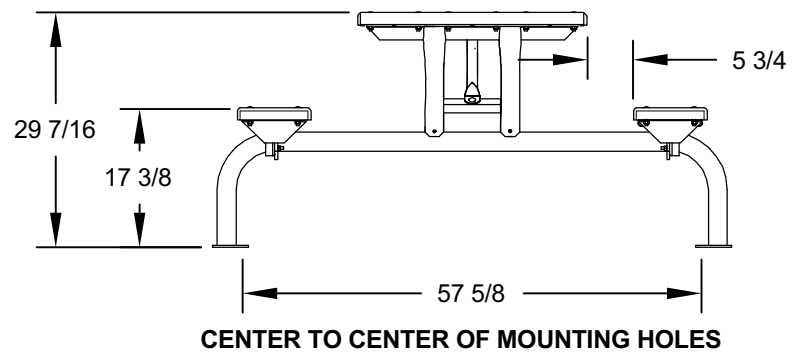
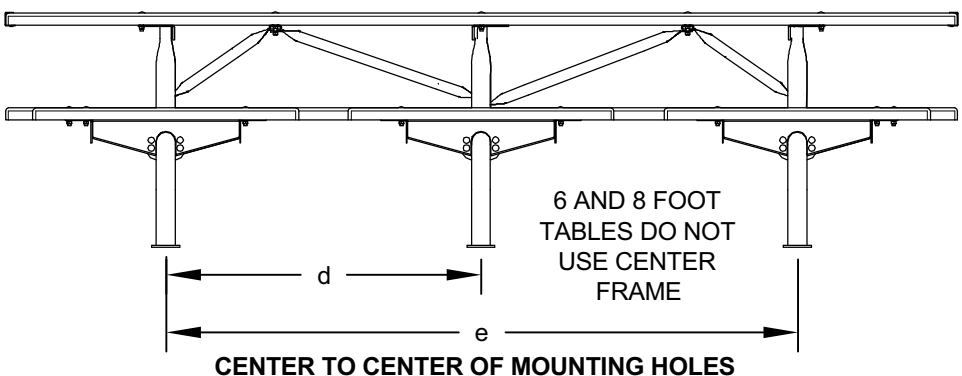

ALL DIMENSIONS IN INCHES

RJThomas Mfg. Co., Inc.
P.O. Box 946 • Cherokee, IA 51012-0946

DRAWN BY
WWM

TITLE T600 SERIES CATERPILLAR STYLE 6, 8, AND 10 FOOT RECTANGULAR TABLE WITH LUMBER TOP AND SEATS

DATE 5-17-10

DWG. NO. AI-1940