



Model UTH/G-6RR/E, 6 ft., Heavy Duty Wheelchair Accessible Portable Table, extended 2 ft. one end, with hot dip galvanized frames and red R-Type thermo-plastic coated perforated steel top and seats

- **ADA compliant wheelchair accessibility at one end**
- **Nontip, nontrip walk-through design**
- **All welded end frames are fabricated from 1.66" diameter steel pipe**
- **Diagonal braces align and strengthen entire table**
- **Frames are hot dip galvanized after fabrication for superior corrosion resistance**
- **Thermo-plastic Coating heat fused to Perforated Steel Top and Seats for durability**
- **Thermo-plastic Coating formulated with U.V. stabilizers for ultraviolet protection**
- **Limited lifetime warranty on frames**

AVAILABLE OPTIONS

- **Powder Coat Finish in choice of colors for steel frame components**
- **Choice of colors of Thermo-plastic Coating**

SPECIFICATIONS:

- **UTH Series** end frames are one-piece welded construction, fabricated from 1.660" O.D. (1-5/8" O.D.) steel pipe to meet 1-1/4" nominal pipe size specifications with 2" x 2" x 1/8" die formed steel angle for attaching the seats and top. "Outriggers" are attached to the frame on the extended end of the table for added stability.
- Table frame design incorporates nontip, nontrip, walk-through design features. Bends are tightly formed to prevent tipping when weight is on one side.
- Table provides one wheelchair space at one end of table by extending the top 2 ft. creating a ADA recommended space of 30" wide, 19" deep, and 27" from ground to bottom of table top for knee space, and minimum 9" above ground extending a total of 24" deep for toe space. Indicated by "/E" at end of model no., e.g. UTH/G-6RW/E.
- A diagonal brace of 1-5/16" O.D. steel pipe and a die-formed steel channel is provided to support extended portions of table top.
- **Model UTH/G-6RW/E** has a nom. 8 ft. long top and 6 ft. long seats. Includes frame stabilizing outriggers.
- Frame design provides a nominal 30" of clearance from ground level to the underside of the table top and nominal seat top height of 21".
- Frames are supported by diagonal braces of 1-5/16" O.D. steel pipe.
- All fasteners are provided for assembly.
- **Standard:** All steel frame components are hot-dip galvanized after fabrication to ASTM-A123 to maintain an average zinc coating of 2.0 oz. per sq. ft. of surface area (indicated by "/G" in model no., e.g. UTH/G-6RW/E).
- **R-Type** table top and seats are each a one-piece welded construction, fabricated from a 14 ga. perforated steel surface with 9/16" dia. holes in a 13/16" center to center in-line pattern and 2" formed 14 ga. steel vertical edges on all sides and reinforced by a strap and die-formed angle substructure. Substructure includes all mounting holes for easy assembly of table.
- **Standard:** All steel surfaces of the top and seats are covered with a thermo-plastic coating in a Brown color (indicated by "RW" in model no., e.g. UTH/G-6RW/E). The UV-stabilized thermo-plastic coating is applied in a multi step process of material preparation and finish application designed to permanently heat fuse and bond the finish to the steel. The thermo-plastic polyethylene finish is impact resistant, does not support mold or mildew, and the textured matte surface is less susceptible to marring and scuffing.
- **Optional:** All steel frame components have powder coat finish. See Specification Bulletin #SPC-CO-001.
- **Optional:** Color choices of Thermo-plastic coated steel components. For optional colors choices see Specification Bulletin #SPC-CO-001.

RJ Thomas Mfg. Co., Inc.

PO Box 946 • Cherokee, IA 51012-0946 • PH: 712-225-5115 • 800-762-5002 • FAX: 712-225-5796
E-mail: pilotrock@rjthomas.com • Web Site: <http://www.pilotrock.com>

© 2018 RJ Thomas Mfg. Co., Inc. PILOT ROCK® Park Products is a registered trademark of RJ Thomas Mfg. Co., Inc.

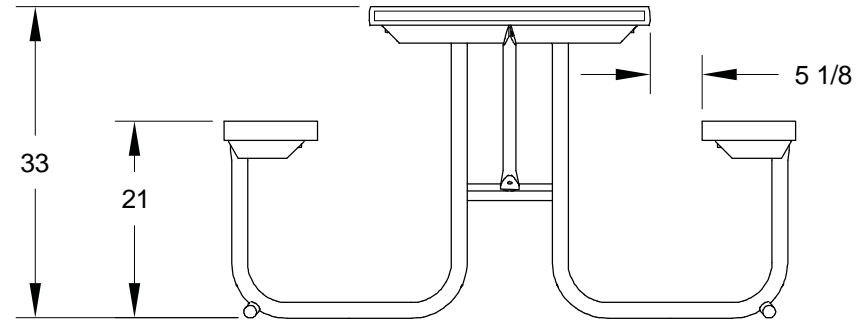
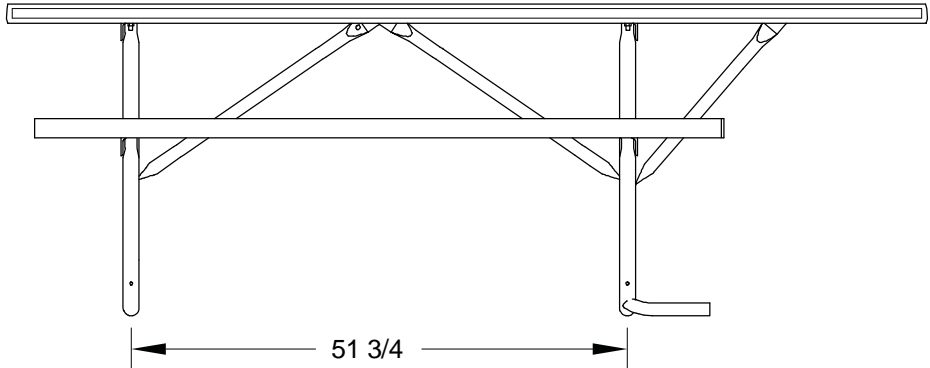
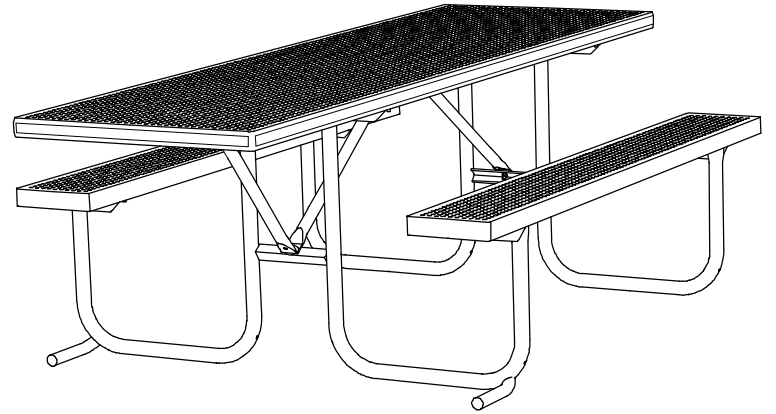
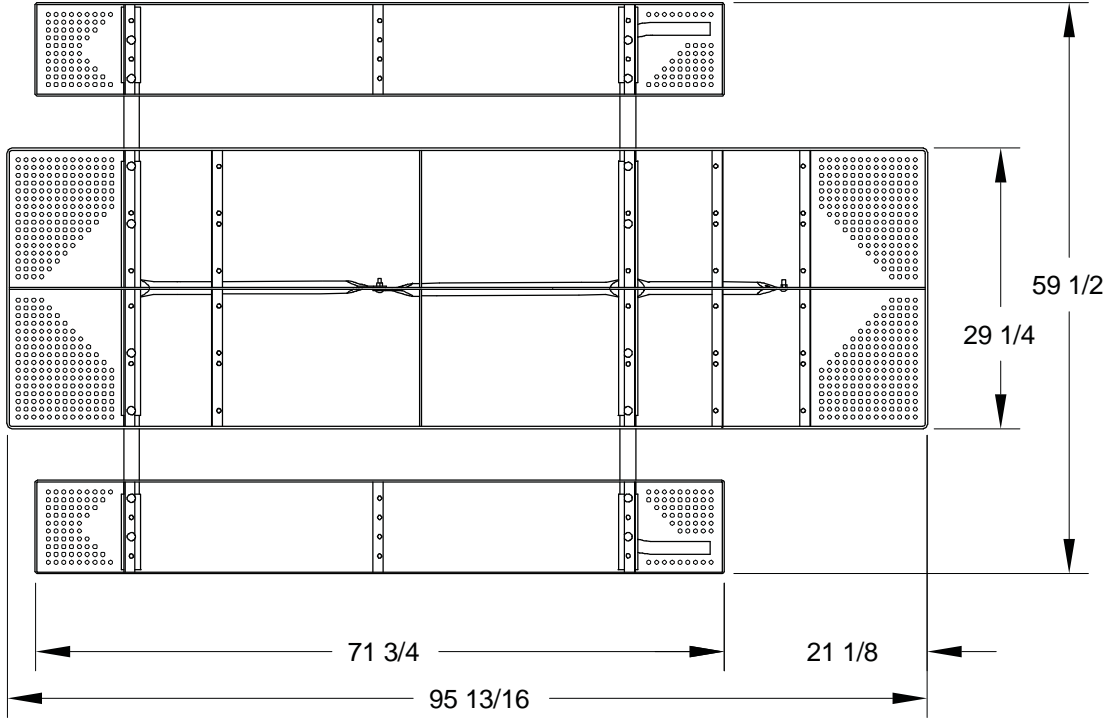

ALL DIMENSIONS IN INCHES

RJ Thomas Mfg. Co., Inc.
P.O. Box 946 • Cherokee, IA 51012-0946

DRAWN BY
WWM

TITLE **UTH SERIES 6 FOOT RAISED TOP PORTABLE RECTANGULAR TABLE
WITH TOP EXTENDED 2 FEET ON ONE END WITH R-TYPE THERMO-PLASTIC
COATED PERFORATED STEEL TOP AND SEATS**

DATE **3-18-10**

DWG. NO. **AI-1830**