



*Model UTK/G-6AL 6 ft. Children's Rectangular Table
with Hot Dip Galvanized frames and Aluminum top and seats*

- **Scaled to fit children up to 12 years of age**
- **Nontip, nontrip, walk-through design**
- **Strong 1-5/8" diameter all welded, steel pipe end frame construction**
- **Frames are hot-dip galvanized after fabrication for superior corrosion resistance**
- **Diagonal bracing for strength and rigidity**
- **Die-formed center channel under table top to support and align top planks**
- **Seats and Top are Aluminum with a clear anodized maintenance free finish**

AVAILABLE OPTIONS

4, 6, or 8 foot lengths

Powder Coat Finish in choice of colors for steel frame components

Powder Coat Finish in choice of colors for aluminum top and seats

SPECIFICATIONS:

- **UTK Series** end frames are one-piece welded construction, fabricated from 1.660" O.D. (1-5/8" O.D.) steel pipe to meet 1-1/4" nominal pipe size specifications with 2" x 2" x 1/8" die formed steel angle for attaching the seats and top.
- Table frame design incorporates nontip, nontrip, walk-through design features. Bends are tightly formed to prevent tipping when weight is on one side.
- **Model UTK/G-4** has a 4 ft. nominal length.
- **Model UTK/G-6** has a 6 ft. nominal length.
- **Model UTK/G-8** has a 8 ft. nominal length.
- Nominal table height is 22". Nominal seat height is 12".
- Frames are supported by diagonal braces of 1-5/16" O.D. steel pipe that connect to a die-formed steel channel designed to align and provide attachment to the table top.
- All galvanized fasteners are provided for assembly.
- **Standard:** All steel frame components are hot-dip galvanized after fabrication to ASTM-A123 to maintain an average zinc coating of 2.0 oz. per sq. ft. of surface area (indicated by "/G" in model no., e.g. UTK/G-4AL).
- Aluminum is extruded 6063-T6 aluminum alloy in planks with dimensions equivalent to that of 2" x 10" nominal sized lumber. The plank design is 1-3/4" x 9-5/8" with four structural reinforcement ribs for greater rigidity. Aluminum planks are provided with a clear anodized finish as per anodizing specification 204 R1. Aluminum clips to fasten planks to frames are included.
- Channel end caps are of extruded 6063-T6 aluminum alloy provided with a clear anodized finish as per anodizing specification 204 R1. End caps are press fitted over ends of aluminum planks and mechanically fastened in place at the factory.
- Table tops are assembled into single units at the factory with one-piece end caps across each end.
- **Optional:** All steel frame components have powder coat finish. See Specification Bulletin #SPC-CO-001.
- **Optional:** Aluminum top and seat planks and end caps have powder coat finish. See Specification Bulletin #SPC-CO-001.

RJ Thomas Mfg. Co., Inc.

PO Box 946 • Cherokee, IA 51012-0946 • PH: 712-225-5115 • 800-762-5002 • FAX: 712-225-5796
E-mail: pilotrock@rjthomas.com • Web Site: <http://www.pilotrock.com>

© 2017 RJ Thomas Mfg. Co., Inc. PILOT ROCK® Park Products is a registered trademark of RJ Thomas Mfg. Co., Inc.

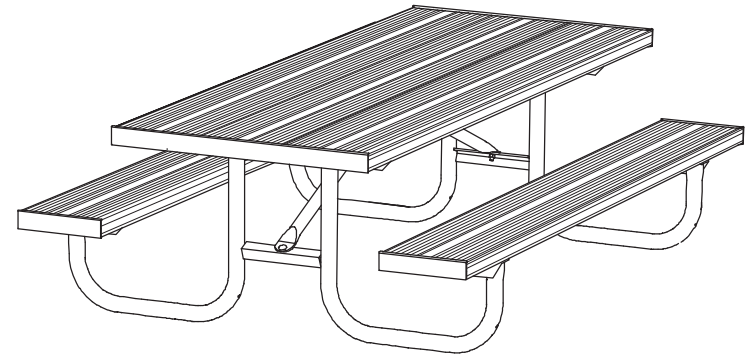
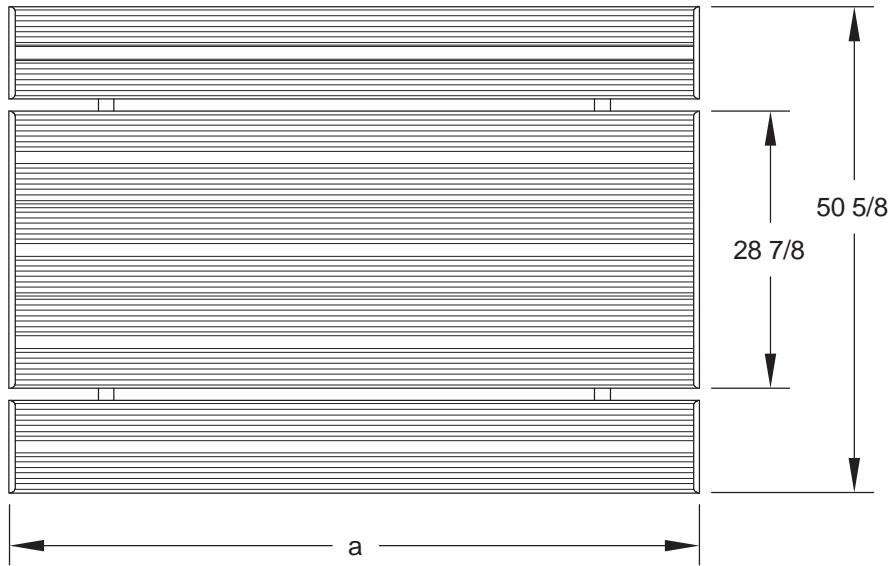

MODEL NUMBER	DIMENSION	
	a	b
UTK-4	48	30
UTK-6	72	51-3/4
UTK-8	96	70

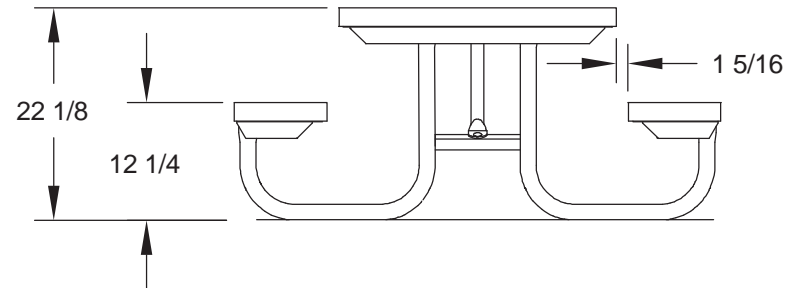
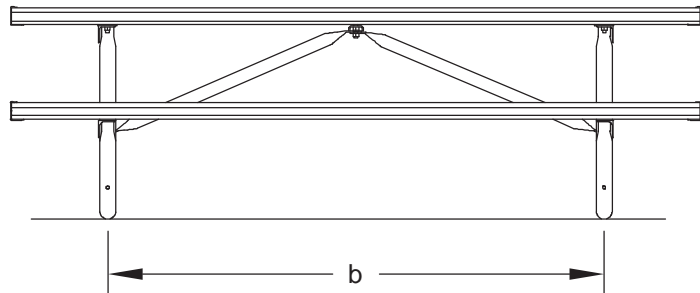

ALL DIMENSIONS IN INCHES

RJThomas Mfg. Co., Inc.
P.O. Box 946 • Cherokee, IA 51012-0946

DRAWN BY
WWM

TITLE UTK SERIES 4, 6, AND 8 FOOT CHILDRENS RECTANGULAR PORTABLE TABLE
WITH ALUMINUM TOP AND SEAT PLANKS

DATE 11-19-08

DWG. NO. AI-1749