



Model WPTS/CW-8AL Universal Accessible portable rectangular table, 8 ft. long with brown powder coated frames and anodized aluminum top and seats

- **Nontip, nontrip, walk-through design, wheelchair accessibility at each end**
- **Full capacity seating when wheelchairs are not in place**
- **All welded end frames are fabricated from 3" x 6" rectangular and 2-1/2" square steel tubing**
- **Diagonal braces align and strengthen entire table**
- **Frames are hot dip galvanized after fabrication for superior corrosion resistance**
- **Structurally reinforced extruded aluminum top and seats with clear anodized finish**

AVAILABLE OPTIONS

6' or 8' lengths

Powder Coat Finish in choice of colors on steel frame components

Powder Coat Finish in choice of colors on Aluminum top and seats

SPECIFICATIONS:

- **WPTS Series** end frames are one-piece welded construction, fabricated from 3" x 6" x 1/8" wall rectangular steel tube top and seat supports connected by 2-1/2" x 1/8" wall square tube with 2" x 2" x 3/16" die-formed steel angle for attaching seats and tops.
- Model WPTS 8-foot frame design provides the ADA recommended wheelchair clearances under the table top of: 30" wide, 27" high and 24" total knee and toe clearance (19" knee + 5" toe) at each end of the table while maintaining full seating capacity of the table.
- Frame design incorporates nontip, nontrip, walk-through features.
- **Model WPTS/G-6** is nom. 6 ft. long, wheelchair accessible both ends with ADA compliant knee/toe clearance.
- **Model WPTS/G-8** is nom. 8 ft. long, wheelchair accessible both ends with ADA compliant knee/toe clearance.
- Nominal table height is 31-5/8". Frame design provides a nominal 28" of clearance from ground level to the underside of table. Nominal seat height is 17-3/4".
- Frames are supported by diagonal braces of 1-5/16" O.D. x 14 ga. wall steel pipe connected to the table top.
- All fasteners are provided for assembly.
- **Standard:** All steel frame components are hot-dip galvanized after fabrication to ASTM-A123 to maintain an average zinc coating of 2.0 oz. per sq. ft. of surface area (indicated by "/G" in model no., e.g. WPTS/G-6AL).
- Aluminum is extruded 6063-T6 aluminum alloy in planks with dimensions equivalent to that of 2" x 10" nominal sized lumber. The plank design is 1-3/4" x 9-5/8" with four structural reinforcement ribs for greater rigidity. Aluminum planks are provided with a clear anodized finish as per anodizing specification 204 R1. Aluminum clips to fasten planks to frames are included.
- Channel end caps are of extruded 6063-T6 aluminum alloy provided with a clear anodized finish as per anodizing specification 204 R1. End caps are press fitted over ends of aluminum planks and mechanically fastened in place at the factory.
- Table top is assembled into single unit at the factory with one-piece end caps across each end.
- **Optional:** All steel frame components have powder coat finish. See Specification Bulletin #SPC-CO-001.
- **Optional:** Aluminum top and seats have powder coat finish in a choice of colors. See Specification Bulletin #SPC-CO-001.
- **U.S. Patent Nos. D489,539; D490,992; D493,291; D496,799; D497,262; 6,918,630**

RJ Thomas Mfg. Co., Inc.

PO Box 946 • Cherokee, IA 51012-0946 • PH: 712-225-5115 • 800-762-5002 • FAX: 712-225-5796

E-mail: pilotrock@rjthomas.com • Web Site: <https://www.pilotrock.com>

© 2020 RJ Thomas Mfg. Co., Inc. PILOT ROCK® Park Products is a registered trademark of RJ Thomas Mfg. Co., Inc.

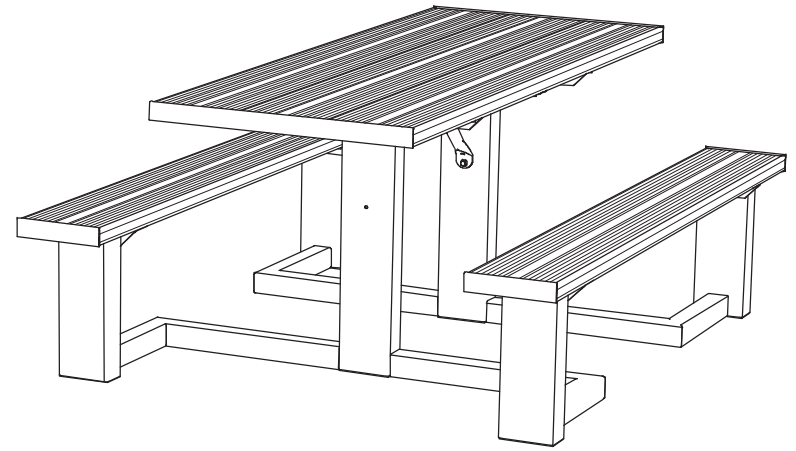
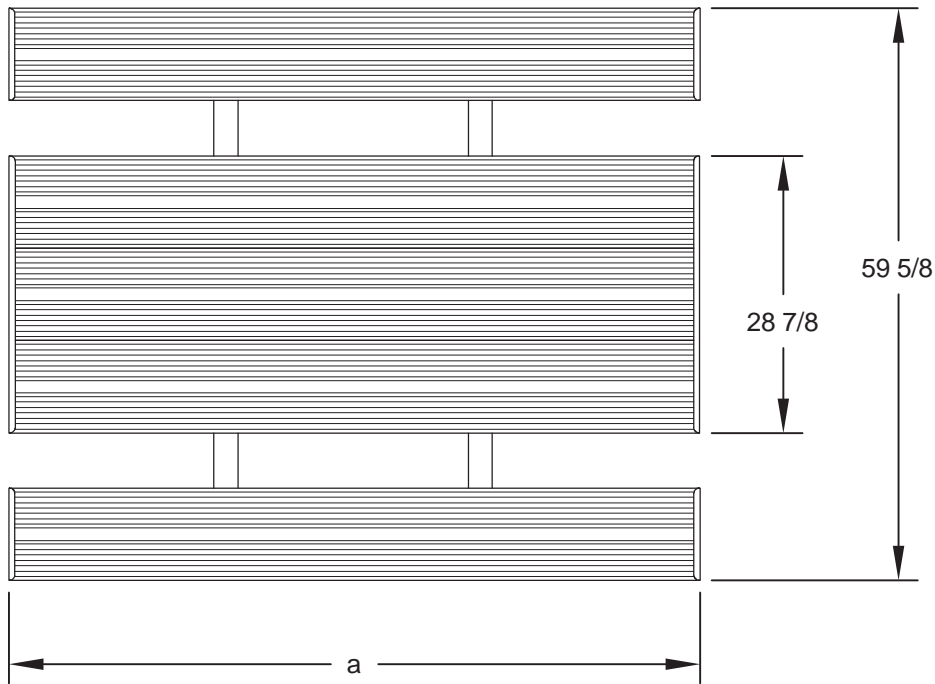

Model Number	DIMENSION	
	a	b
WPTS-6	72	23 1/2
WPTS-8	96	41 3/4

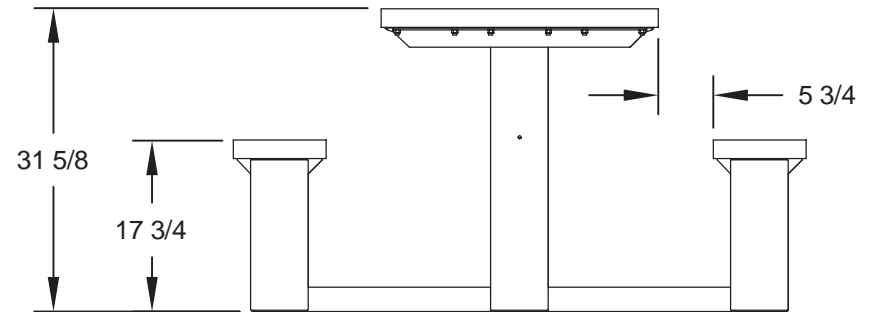
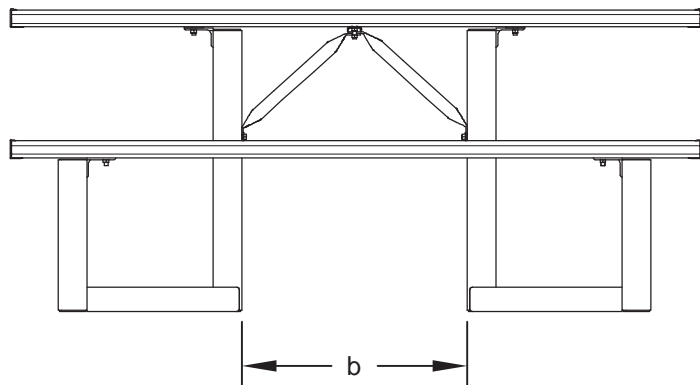

ALL DIMENSIONS IN INCHES

RJThomas Mfg. Co., Inc.
P.O. Box 946 • Cherokee, IA 51012-0946

DRAWN BY
WWM

TITLE WPTS SERIES 6 AND 8 FOOT UNIVERSAL ACCESS RECTANGULAR TABLE WITH ALUMINUM TOP AND SEATS

DATE 5-27-10

DWG. NO. AI-1945