



*Model WPTS/G-6PN Universal accessible portable rectangular table,  
6 ft. long with Hot Dip Galvanized frames  
and Green Recycled Plastic top and seats*

- **Nontip, nontrip, walk-through design, wheelchair accessibility at each end**
- **Full capacity seating when wheelchairs are not in place**
- **All welded end frames are fabricated from 3" x 6" rectangular and 2-1/2" square steel tubing**
- **Diagonal braces align and strengthen entire table**
- **Frames are hot dip galvanized after fabrication for superior corrosion resistance**
- **100% Recycled Plastic Seat and Top Planks with solid color and U.V. stabilizer for ultraviolet protection**

#### AVAILABLE OPTIONS

- **6' or 8' lengths**
- **Powder Coat Finish in choice of colors on steel frame components**
- **Choice of colors of Recycled Plastic**

#### SPECIFICATIONS:

- **WPTS Series** end frames are one-piece welded construction, fabricated from 3" x 6" x 1/8" wall rectangular steel tube top and seat supports connected by 2-1/2" x 1/8" wall square tube with 2" x 2" x 3/16" die-formed steel angle for attaching seats and tops.
- Model WPTS 8-foot frame design provides the ADA recommended wheelchair clearances under the table top of: 30" wide, 27" high and 24" total knee and toe clearance (19" knee + 5" toe) at each end of the table while maintaining full seating capacity of the table.
- Frame design incorporates nontip, nontrip, walk-through features.
- **Model WPTS/G-6** is nom. 6 ft. long, wheelchair accessible both ends, but slightly short of total knee/toe clearance to be ADA compliant.
- **Model WPTS/G-8** is nom. 8 ft. long, wheelchair accessible both ends with ADA compliant knee/toe clearance.
- Nominal table height is 31". Frame design provides a nominal 28" of clearance from ground level to the underside of table. Nominal seat height is 18".
- Frames are supported by diagonal braces of 1-5/16" O.D. x 14 ga. wall steel pipe connected to the table top.
- All fasteners are provided for assembly.
- **Standard:** All steel frame components are hot-dip galvanized after fabrication to ASTM-A123 to maintain an average zinc coating of 2.0 oz. per sq. ft. of surface area (indicated by "/G" in model no., e.g. WPTS/G-6PC).
- **Standard:** Top and seats are made of 100% Recycled Plastic molded into 2" x 10" nominal sized planks with solid Cedar color (indicated by "PC" in model no., e.g. WPTS/G-6PC) formed throughout and a U.V. stabilizer added for ultra-violet protection.
- Recycled Plastic table top and seat planks are supported by pregalvanized steel subframe channels.
- **Optional:** All steel frame components have powder coat finish. See Specification Bulletin #SPC-CO-001.
- **Optional:** Color choices of recycled plastic components. See Specification Bulletin #SPC-CO-001.
- **U.S. Patent Nos. D489,539; D490,992; D493,291; D496,799; D497,262; 6,918,630**

**RJ Thomas Mfg. Co., Inc.**

PO Box 946 • Cherokee, IA 51012-0946 • PH: 712-225-5115 • 800-762-5002 • FAX: 712-225-5796  
E-mail: pilotrock@rjthomas.com • Web Site: <http://www.pilotrock.com>

© 2018 RJ Thomas Mfg. Co., Inc. PILOT ROCK® Park Products is a registered trademark of RJ Thomas Mfg. Co., Inc.

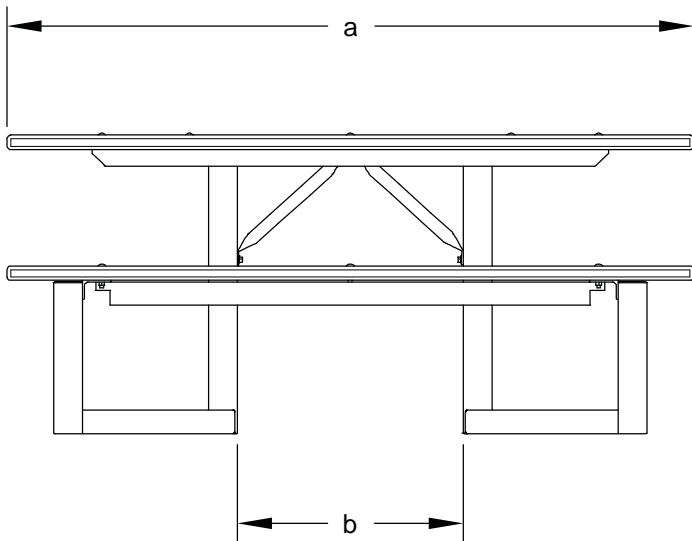
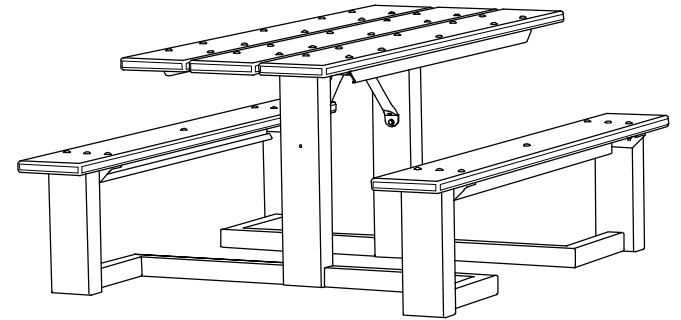
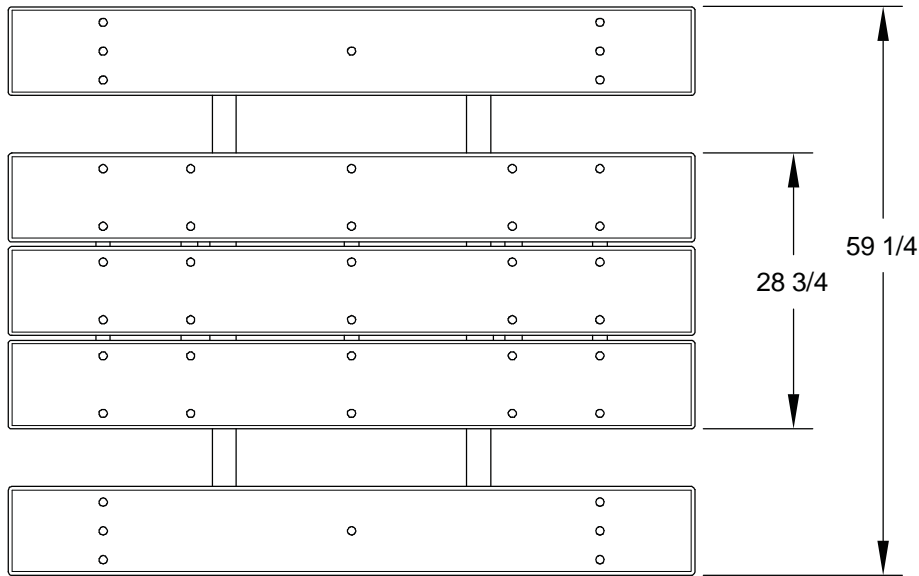

MODEL NUMBER	DIMENSION	
	a	b
WPTS-6	71 1/2	23 1/2
WPTS-8	95 1/2	14 3/4

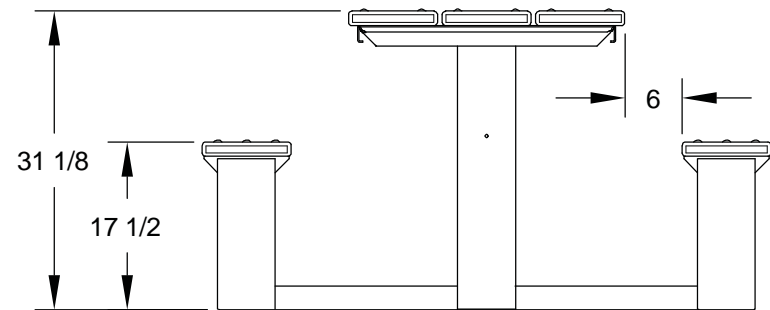

ALL DIMENSIONS IN INCHES

**RJThomas Mfg. Co., Inc.**  
P.O. Box 946 • Cherokee, IA 51012-0946

DRAWN BY  
**WWM**

TITLE  
WPTS SERIES 6 AND 8 FOOT UNIVERSAL ACCESS TABLES WITH 2" X 10"  
RECYCLED PLASTIC TOP AND SEAT PLANKS

DATE 11-19-08

DWG. NO. AI-1832