

XTX Series Extra Heavy Duty Portable Rectangular Utility Tables with 100% Recycled Plastic Top



Model XTX/CY-6PR 6 Ft. Extra Heavy Duty Portable Rectangular Utility Table with yellow powder coated frames and red 100% recycled plastic top

- **Constructed specifically for heavy use areas**
- **All welded end frames are fabricated from 2-3/8" diameter steel pipe**
- **Die-formed center channel and diagonal braces align and strengthen entire table**
- **Frames are hot dip galvanized after fabrication for superior corrosion resistance**
- **100% Recycled Plastic Top Planks with solid color and U.V. stabilizer for ultraviolet protection**
- **Steel channel reinforcements under table top**

SPECIFICATIONS:

- **XTX Series** end frames are one-piece welded construction, fabricated from 2.375" O.D. (2-3/8" O.D.) steel pipe to meet 2" nominal steel pipe size specifications with 2" x 2" x 3/16" A-36 structural grade steel angle for attaching the top. Frame foot is formed with flattened and rounded ends. A 9/16" hole is provided in each end of foot for optional surface mounting with concrete anchors (anchors not included).
- **Model XTX/G-6** is a nominal 6 ft. long.
- **Model XTX/G-8** is a nominal 8 ft. long.
- Nominal table height is 30".
- Frames are supported by diagonal braces of 1-5/16" O.D. steel pipe that connect to a die-formed steel channel designed to align and provide attachment to the table top.
- **Standard:** All steel frame components are hot-dip galvanized after fabrication to ASTM-A123 to maintain an average zinc coating of 2.0 oz. per sq. ft. of surface area (indicated by "/G" in model no., e.g. XTX/G-8PW).
- All galvanized fasteners are provided for assembly.
- **Standard:** Top is made of 100% Recycled Plastic molded into 2" x 10" nominal sized planks with solid cedar colored color (indicated by PC in model no., e.g. XTX/G-6PC) formed throughout and a U.V. stabilizer added for ultra-violet protection.
- Recycled Plastic table top planks are supported by pregalvanized steel subframe channels.
- **Optional:** Color choices of powder coated steel frame components. See Specification Bulletin #SPC-CO-001.
- **Optional:** Color choices of Recycled Plastic components. See Specification Bulletin #SPC-CO-001.

AVAILABLE OPTIONS

- **6' and 8' lengths**
- **Powder Coat Finish in choice of colors for steel frame components**
- **Choice of colors of Recycled Plastic**

RJThomas Mfg. Co., Inc.

PO Box 946 • Cherokee, IA 51012-0946 • PH: 712-225-5115 • 800-762-5002 • FAX: 712-225-5796

E-Mail: pilotrock@rjthomas.com • Web Site: <http://www.pilotrock.com>

© 2011 RJThomas Mfg. Co., Inc. PILOT ROCK® Park Products is a registered trademark of RJThomas Mfg. Co., Inc.

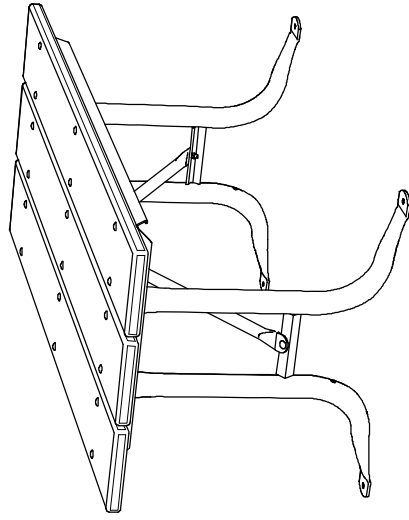

MODEL	DIMENSIONS	
	a	b
XTX-6	71 1/2	51 3/4
XTX-8	95	70

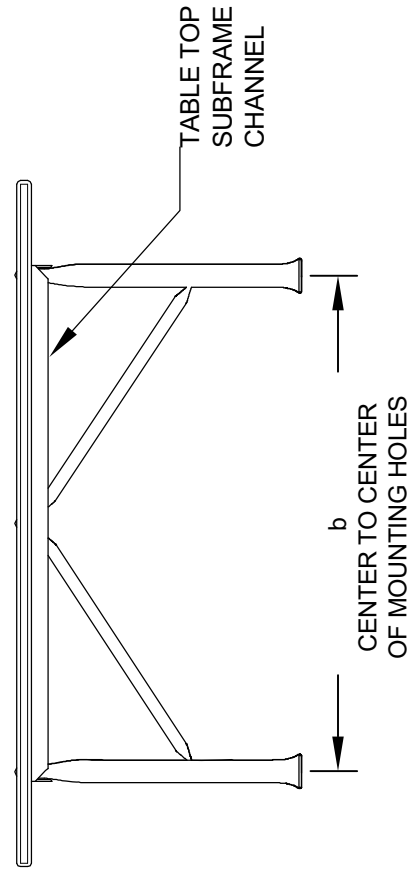
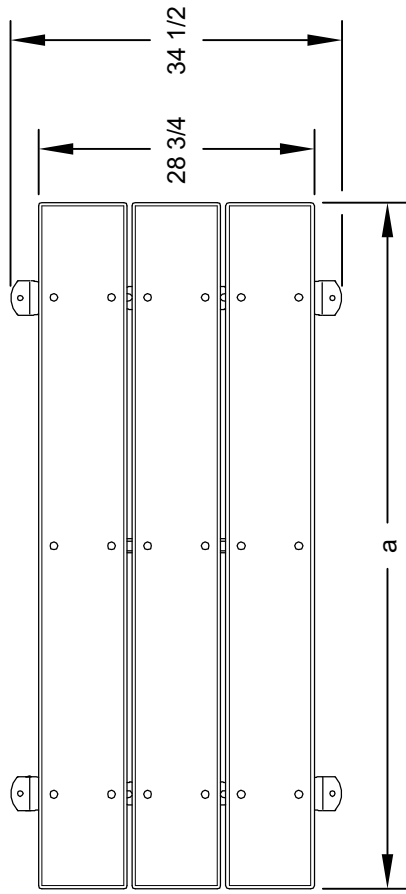
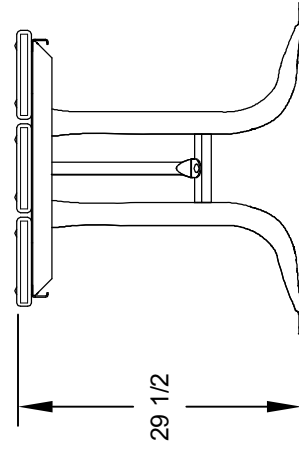

ALL DIMENSIONS IN INCHES

RJ Thomas Mfg. Co., Inc.
 P.O. Box 946 • Cherokee, IA 51012-0946

DRAWN BY
WWM

TITLE XTX SERIES 6 AND 8 FT PORTABLE, RECTANGULAR UTILITY TABLE
 WITH RECYCLED PLASTIC TOP

DATE 3-14-11

DWG. NO. **AI-2001**